

Compressors and Condensing Units

Hermetic, Water-Cooled

INDEX

MODEL	ELECTRICAL CHARACTERISTICS (60-Hz)				SCHEMATIC DIAGRAM AND COMPONENT ARRANGEMENT FIG. NO.		LABEL DIAGRAM NO.		STARTING SERIAL NO.
	Volts/Phase								
	230/1	200/3	230/3	460/3					
07DA102-	300	400	500	600	1 (1 ph)	2 (3 ph)	07DA-500123 (1 ph)	07DA-500133 (3 ph)	H112827
07DA203-	300	400	500	600					
07DA103-	300	400	500	600					
07DA106-	300	400	500	600					
07DA208-	--	400	500	600					
07DA,B210-	--	400	500	600					
07DB112-	--	400	500	600					
07DB215-	--	400	500	600					
06DA7181CAO-	--	400	500	600	2 (3 ph)	07DA500133 (3 ph)			
06DA8181AAO-	--	400	500	600					
06DE8241DAO-	--	400	500	600					
06DE3371BAO-	--	400	500	600					
06DA,E5371BE0-	--	400	500	600					

06D Compressor Terminal Diagrams

Accessory Electric Solenoid Unloader Wiring

Recommended Field Wiring

Fig 3
Fig 4
Fig 5

Unit model number for indicated electrical characteristics
Example: 07DA106500 is a 230-v, 3-ph, 60-Hz unit

FIELD WIRING

All units are factory wired for single-pumpout control (with field addition of pilot duty control and liquid line solenoid valve). Wiring may be modified for automatic pumpdown control as shown in Fig. 5. See 06D,07D Installation, Start-Up and Service Instructions for further details.

Do not use single-pumpout or automatic pumpdown control on dry-expansion cooler applications. For these applications, modify single-pumpout control by removing pumpout relay. Do not use automatic pumpdown control with compressor equipped with cylinder head bypass unloaders.

LEGEND

- C** - Contactor
 - CR** - Control Relay
 - HP** - High Pressurestat
 - HR** - Holding Relay
 - IT** - Internal Motor Thermostat
 - LP** - Lo Pressurestat
 - M3** - Evaporator Fan or Chilled Water Pump
 - M4** - Cooling Tower Pump, Air-Cooled or Evaporative Condenser Fan
 - M5** - Cooling Tower Fan or Evaporative Condenser Pump
 - OL** - Overload Relay
 - PO** - Pumpout Relay
 - RC** - Run Capacitor
 - SC** - Start Capacitor
 - SR** - Start Relay
 - SV** - Solenoid Valve
 - TM** - Timer Motor
 - US** - Unloader Solenoid
- Factory Wiring
Field Wiring
Terminal Block Connections

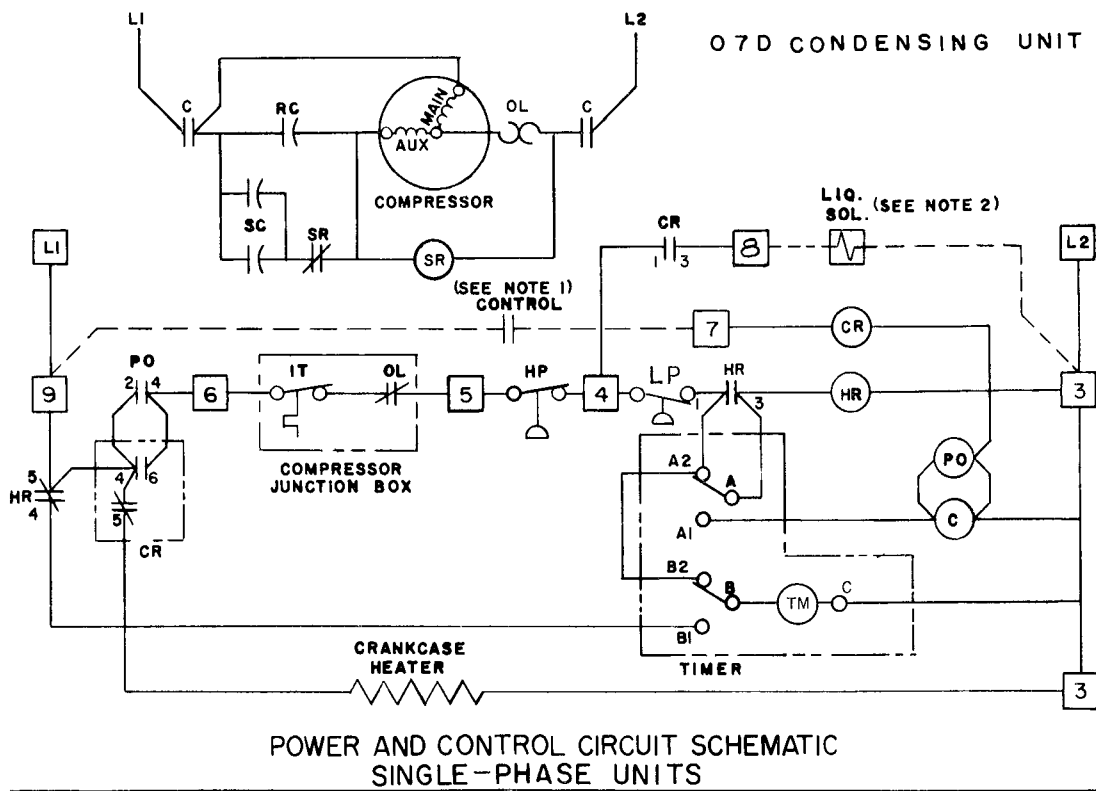

CAUTION-OPEN BOTH DISCONNECT SWITCHES BEFORE SERVICING

NOTES

- 1 Pilot duty control must be field supplied. Min contact rating must be 25 va
- 2 Liquid line solenoid valve must be field supplied and fused in accordance with NEC max load 50 va holding, 200 va inrush
- 3 Control circuit is 230 v. A separate source of supply must be field supplied thru a fused disconnect device with a max rating of 15 amps to terminal block terminals
- 4 Open control circuit disconnect switch for servicing only. Disconnect must remain closed for cranks case heater to operate

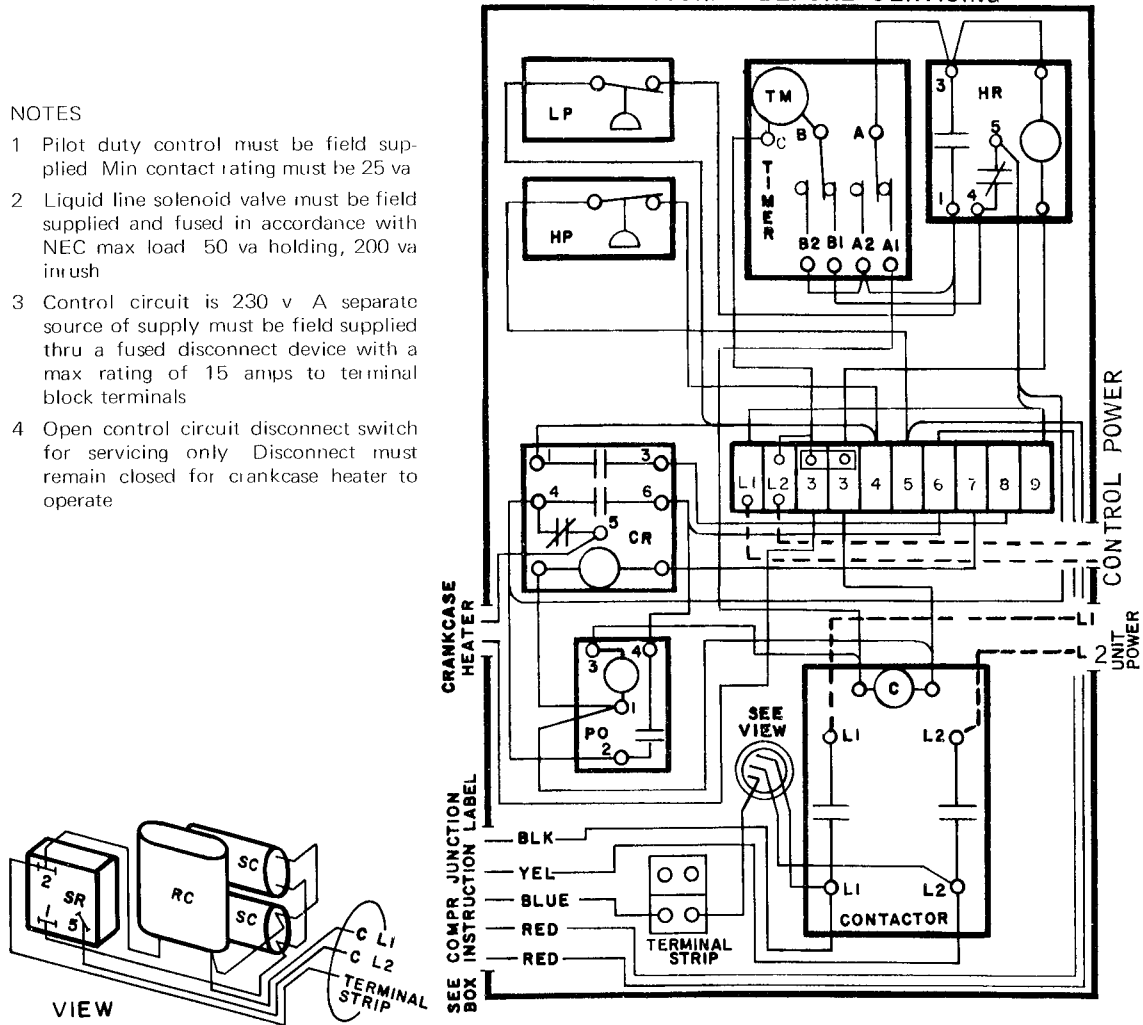

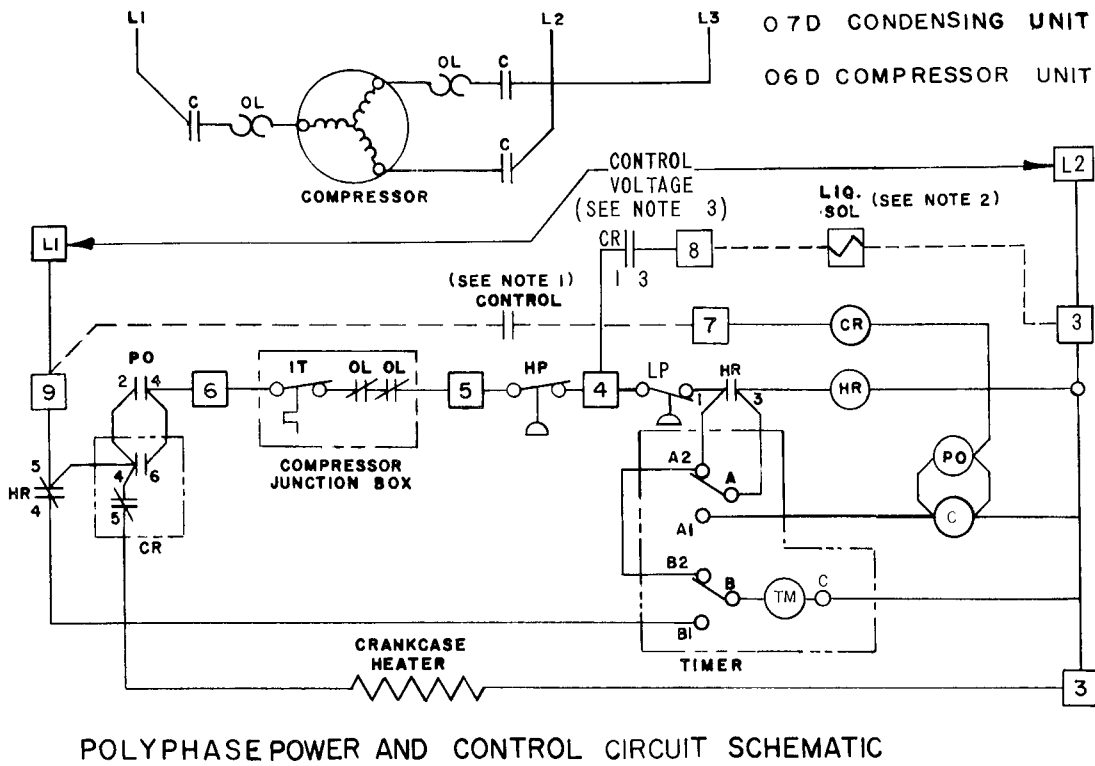

CAUTION - OPEN BOTH DISCONNECT SWITCHES BEFORE SERVICING

NOTES

- 1 Pilot duty control must be field supplied Min contact rating must be 25 va
- 2 Liquid line solenoid valve must be field supplied and fused in accordance with NEC max load 50 va holding, 200 va inrush
3. 200-v and 230-v units have 230-v control circuit 460- and 575-v units have 115-v control circuit A separate source of supply at the correct voltage must be field supplied thru a fused disconnect device with a max rating of 15 amps to terminal block terminals L1 L2
4. A transformer of the following rating may be field supplied for 460-v and 575-v units
All 07D()112, 07D()215, 06D()337, 06D()537 and 06D()824 units 150 va
All other units 100 va
- 5 Open control circuit disconnect switch for servicing only Disconnect must remain closed for crankcase heater to operate
- 6 Transformer must be fused and grounded per applicable codes

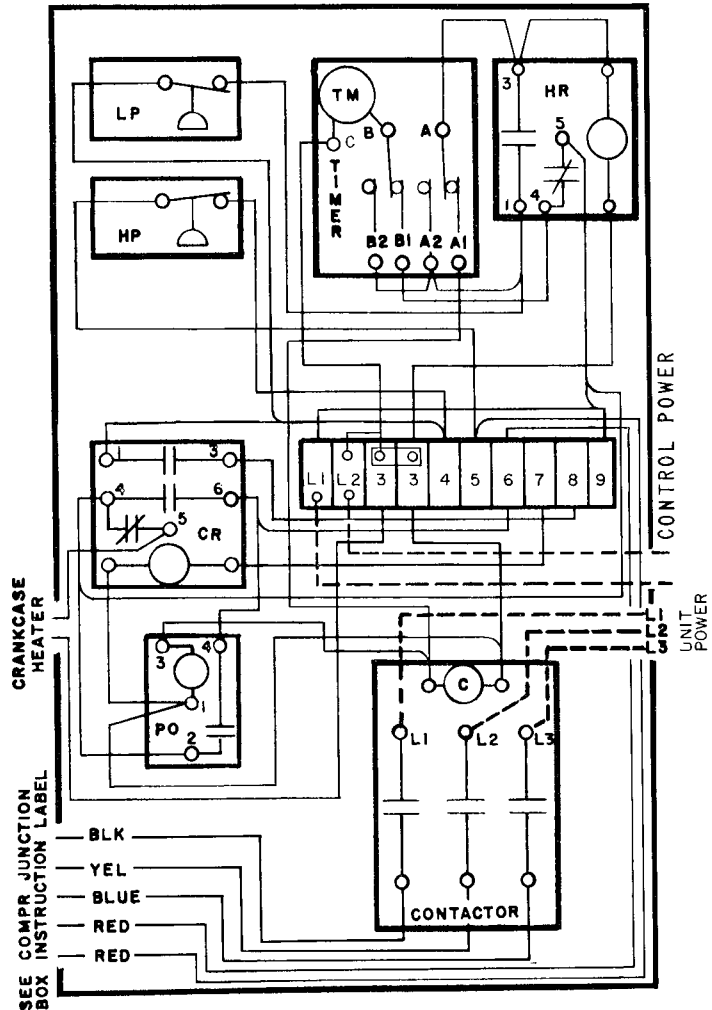
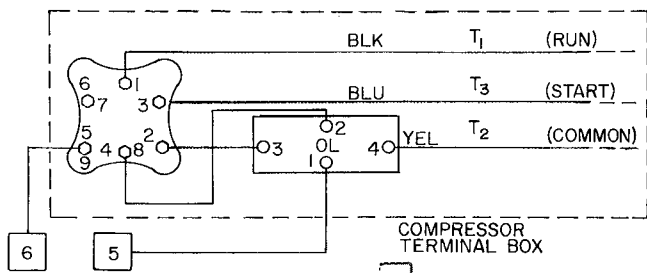
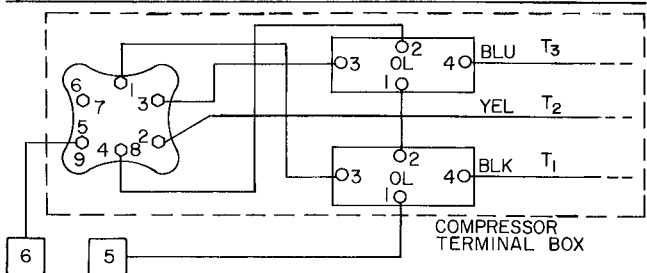

Fig. 2 - 06D, 07D Label Diagram (200-3-60, 230-3-60 and 460-3-60)



1 - PHASE A



3-PHASE - 2- AND 4-CYLINDER B

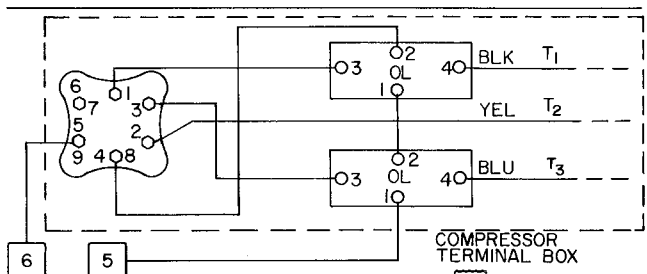

3-PHASE - 6-CYLINDER C

UNITS		
A	B	C
07DA102	06DA718	06DE824
07DA203	06DA818	06DE337
07DA103	07DA102	06DA, E537
07DA106	07DA203	07DA, B210
	07DA103	07DB112
	07DA106	07DB215
	07DA208	

Fig. 3 - 06D Compressor Terminal Diagrams

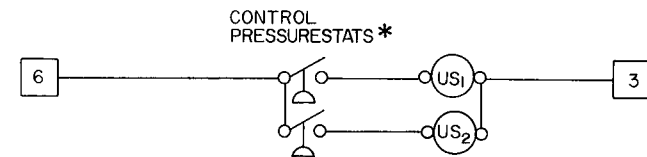

*Control pressurestats or thermostats are field supplied
NOTE Solenoids unload compressor when they are energized

Fig. 4 - Accessory Electric Solenoid Unloader Wiring

SINGLE-PUMPOUT CONTROL

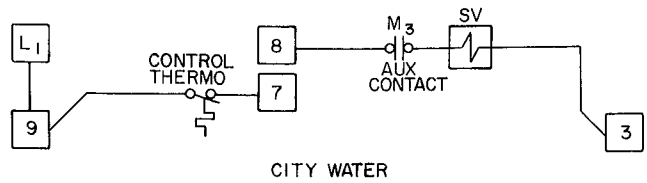

CITY WATER

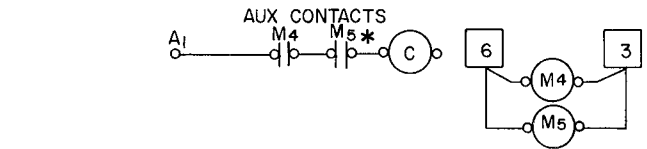
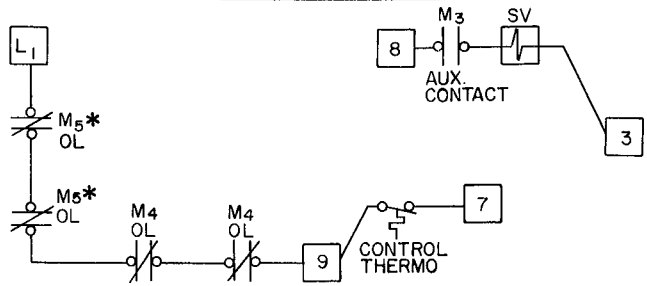

COOLING TOWER; AIR-COOLED CONDENSER; EVAPORATIVE CONDENSER

AUTOMATIC PUMPDOWN CONTROL

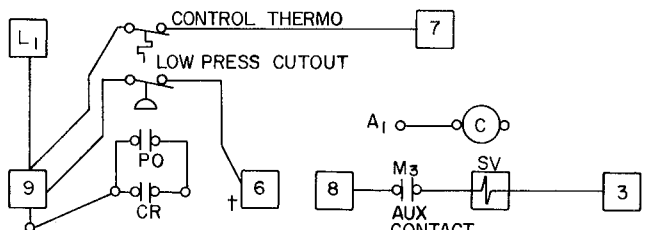

CITY WATER

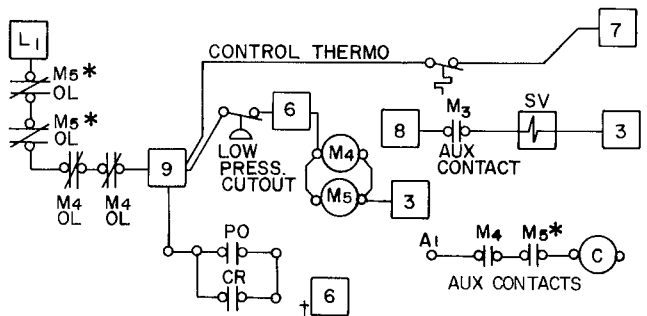

COOLING TOWER; AIR-COOLED CONDENSER; EVAPORATIVE CONDENSER

*Optional
†Remove connection between 6 and CR normally open contact

Fig. 5 - Recommended Field Wiring

Manufacturer reserves the right to discontinue, or change at any time, specifications or designs without notice and without incurring obligations.

CARRIER AIR CONDITIONING COMPANY • SYRACUSE, NEW YORK