

Compressors and Condensing Units

Hermetic, Water-Cooled

INDEX (60-Hertz)

UNIT	VOLTS	PHASE	FIG. NO.	DESCRIPTION	LABEL DIAG 07DA500	
06D A818 E824 E537	200, 230, 460	3	1	Schematic Diagram and Component Arrangement	183	
	07D A106 A208 B210 B215	200, 230, 460	3			1
		A106	230			1
06D Compr			3	Terminal Diagrams	-	
All 06D & 07D	All	All	4	Access Elec Solenoid Unloader Wiring	-	
			5	Recommended Field Wiring	-	

MODEL NUMBERS

VOLTS	PHASE	MODEL
230	1	300
200	3	400
230		500
460		600

FIELD WIRING

All units are factory wired for single-pumpout control (with field addition of pilot duty control and liquid line solenoid valve) Wiring may be modified for automatic pumpdown control as shown in Fig. 5. See 06D,07D Installation, Start-Up and Service Instructions for further details.

→ Do not use automatic pumpdown control on dry-expansion cooler applications or when compressor is equipped with cylinder head bypass unloaders.

GENERAL NOTES

1. Factory wiring is in accordance with National Electrical Code (NEC). Field modifications or additions must comply with all applicable codes.
2. If any of the original furnished wiring must be replaced, Type 90 C wire, or equivalent, must be used.
3. Use copper, copper-clad aluminum or aluminum conductors for field power supply.
4. Field power supply wiring must be rated 75 C minimum.
5. Compressor is thermally protected. Three-phase motors are protected against primary single phasing conditions.
6. Pilot duty control must be field supplied. Minimum contact rating must be 25 va.
7. The 200- and 230-volt units have 230-volt control circuit; 460-volt units have 115-volt control circuit. A separate source of control power at the correct voltage must be field supplied thru a fused disconnect device with a maximum rating of 15 amps. Connect control circuit leads to terminals L1 and L2 on TB2.
8. The fused disconnects for incoming power wiring (unit and control) must be within sight of the unit and readily accessible in accordance with National Electrical Code (NEC) Article 440-14.
9. Control circuit disconnect switch must remain closed for crankcase heater to operate. *Open only when servicing unit or for a prolonged shutdown.*
- 10. For 460-volt units, a control circuit transformer rated as follows may be field-supplied:
150 va for 06DE824, E537, and 07DB215;
100 va for 06DA818 and 07DA106, A208, B210.
11. Transformer must be used and grounded in accordance with all applicable codes.
12. Liquid line solenoid valve (LLS) must be field supplied and wired in accordance with National Electrical Code (NEC). Maximum load. 50 va holding, 200 va inrush.

SCHEMATIC

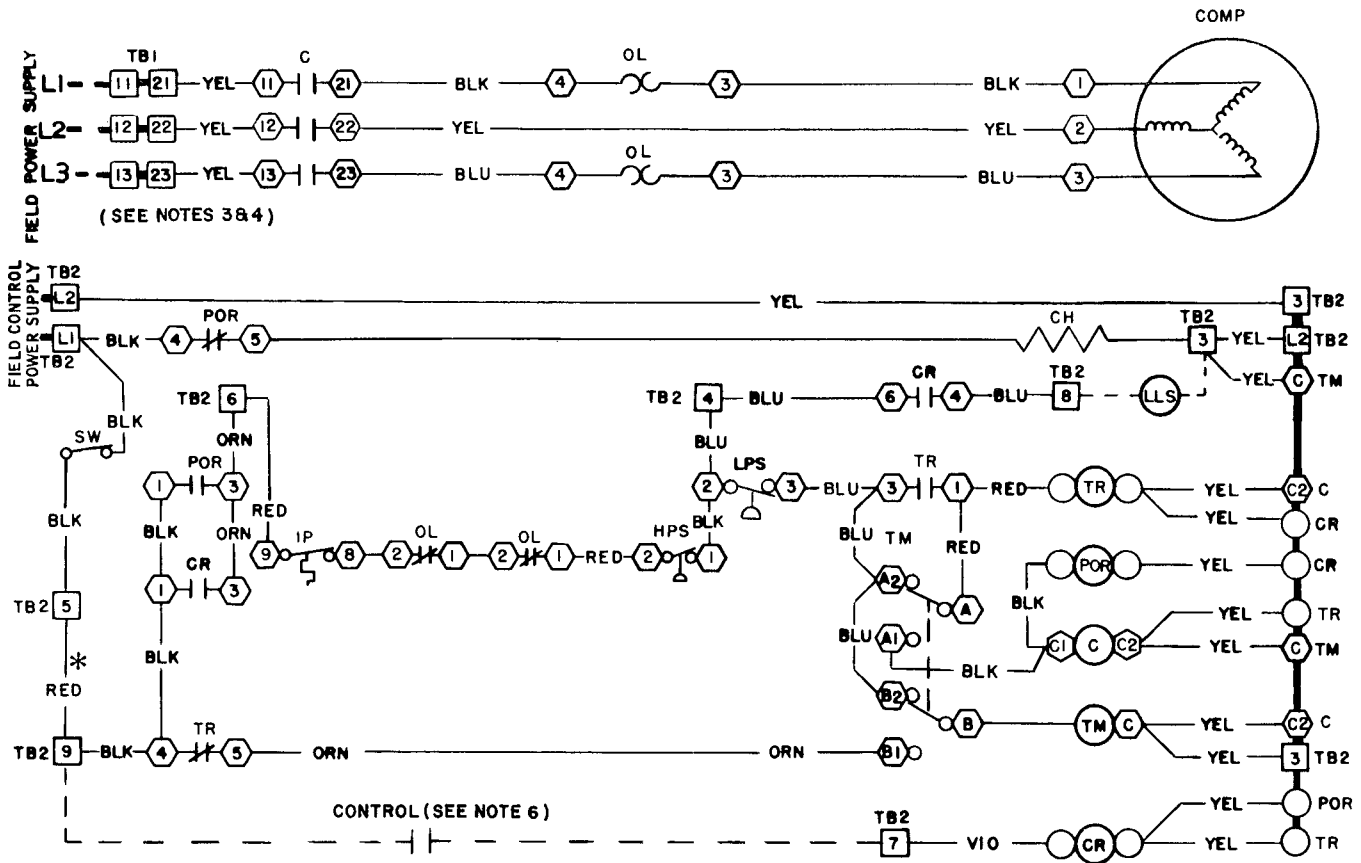

LEGEND

- C — Contactor
 - CH — Crankcase Heater
 - Comp — Compressor Motor
 - CR — Control Relay
 - Equip Gnd — Equipment Ground Conn
 - HPS — High Pressure Switch
 - IP — Internal Protector
 - LLS — Liquid Line Solenoid
 - LPS — Low Pressure Switch
 - NEC — National Electrical Code
 - OI — Overload Relay
 - POR — Pumpout Relay
 - Sw — Switch
 - TB — Terminal Block
 - TM — Timer Motor
 - TR — Timer Relay
- Terminal Block Connections
 Marked Component Connections
 Unmarked Component Connections
 Factory Wiring
 Field Wiring
 Indicates common potential (does not represent a wire)

*Insert Safety Interlocks (when used) between terminals 5 and 9 on TB2

COMPONENT ARRANGEMENT

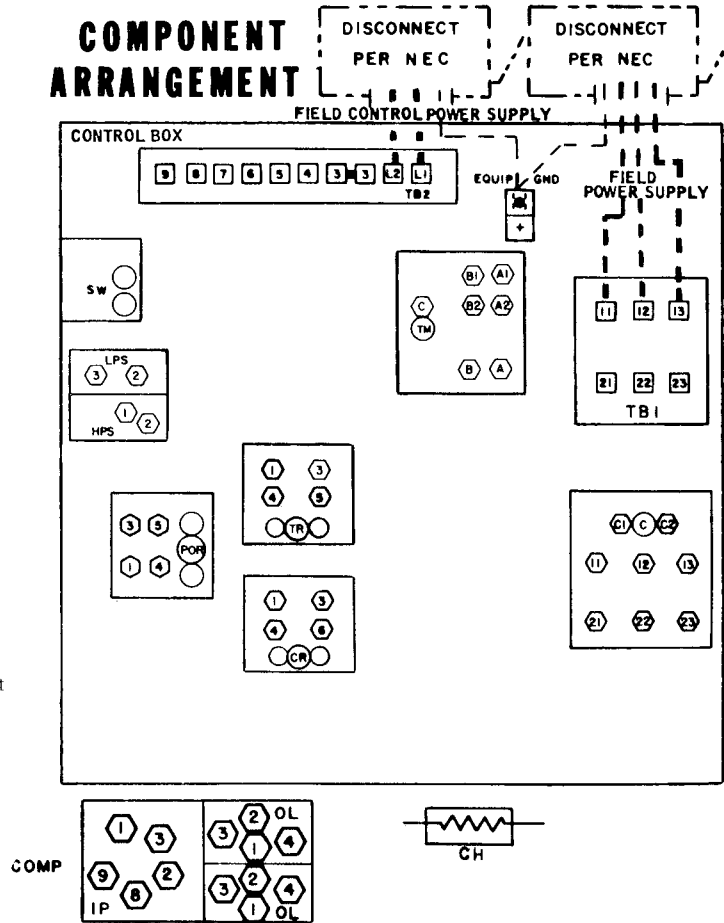

→ Fig. 1 — Schematic Diagram and Component Arrangement; 06D,07D; 200-, 230-, 460-3-60

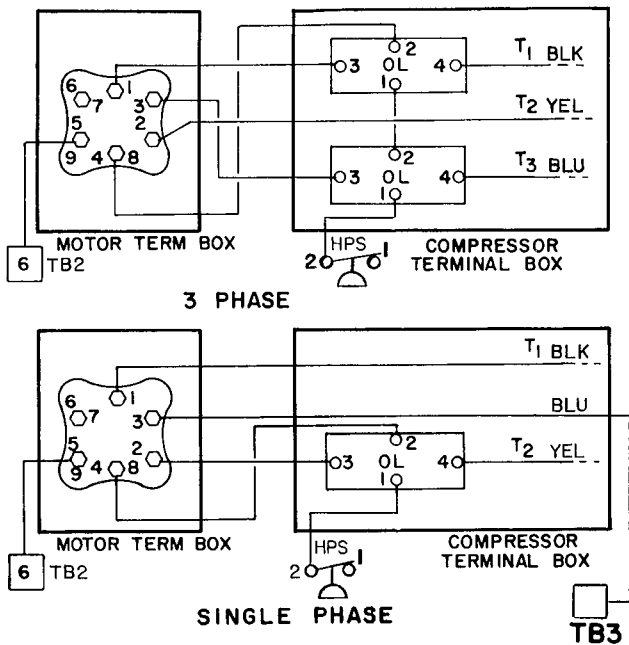

Single Phase: 07DA106
 Three Phase 06DA818, E824, E537; 07DA106, A208, B210, B215

→ Fig. 3 – Compressor Terminal Diagrams

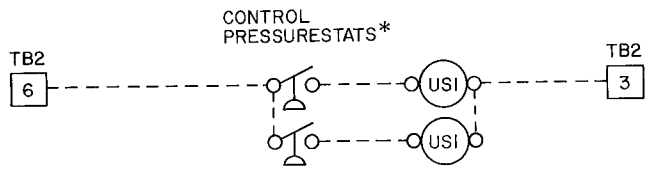

*Control pressurestats or thermostats are field supplied
 NOTE Solenoids unload compressor when they are energized

Fig. 4 – Accessory Electric Solenoid Unloader Wiring

LEGEND (Fig. 3, 4, 5)

- Aux – Auxiliary
 - C – Contactor
 - CR – Control Relay
 - HPS – High Pressure Switch
 - LLS – Liquid Line Solenoid Valve
 - LPS – Low Pressure Switch
 - M₃ – Evaporator Fan or Chilled Water Pump
 - M₄ – Cooling Tower Pump, Air-Cooled or Evaporative Condenser Fan
 - M₅ – Cooling Tower Fan or Evaporative Condenser Pump
 - OI – Overload Relay
 - POR – Pumpout Relay
 - Sw – Switch
 - TB – Terminal Block
 - TR – Timer Relay
 - US – Compressor Unloader Solenoid
- Factory Wiring
 - - - Field Wiring

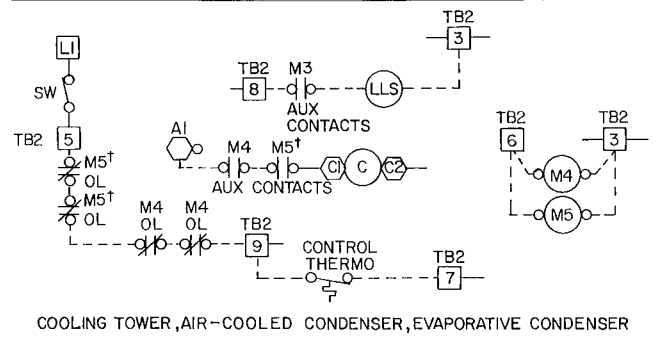
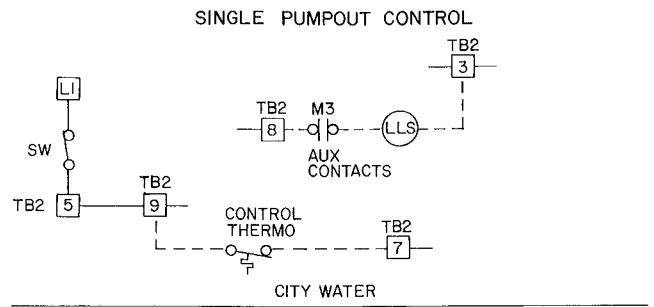

AUTOMATIC PUMPDOWN CONTROL

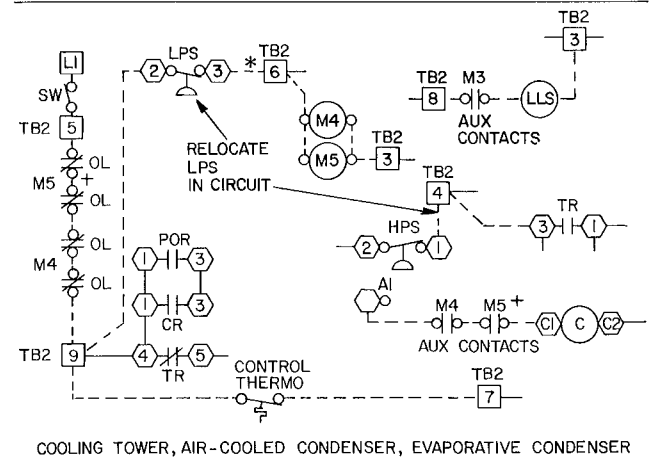
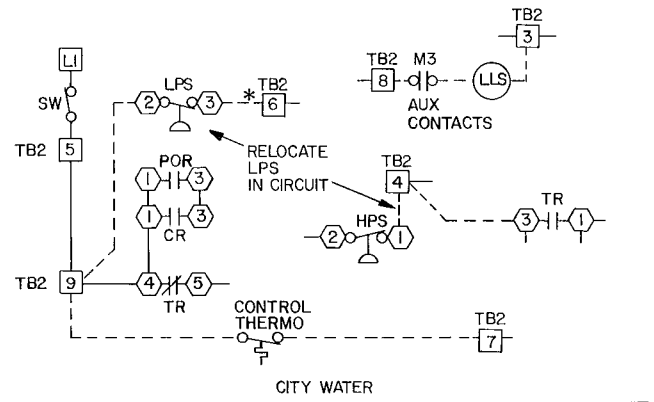

*Disconnect wire from terminal 3 on POR normally open contacts and connect to terminal 3 on LPS
 †Optional

→ Fig. 5 – Recommended Field Wiring

Manufacturer reserves the right to discontinue, or change at any time, specifications or designs without notice and without incurring obligations.