

## Compressors and Condensing Units

### Hermetic, Water-Cooled

This publication covers the change to the use of extended voltage (208/230-3-60) motors in 06D compressors. The control voltage for all 60-Hz units is 115 volts, single phase.

#### GENERAL NOTES

1. Factory wiring is in accordance with National Electrical Code (NEC). Field modifications or additions must comply with all applicable codes.
2. If any of the original furnished wiring must be replaced, Type 90 C, minimum, wire must be used.
3. Use copper, copper-clad aluminum or aluminum conductors for field power supply.
4. Field power supply wiring must be rated 75 C minimum.
5. Compressor is thermally protected. Three-phase motors are protected against primary single phasing conditions.
6. Pilot duty control must be field supplied. Minimum contact rating must be 25 va.
7. All units have 115-volt control circuit. A separate source of control power at the correct voltage must be field supplied thru a fused disconnect device with a maximum rating of 15 amps. Connect control circuit leads to terminals L1 and L2 on TB2.
8. The fused disconnects for incoming power wiring (unit and control) must be within sight from the unit and readily accessible in accordance with National Electrical Code (NEC) Article 440-14.
9. Control circuit disconnect switch must remain closed for crankcase heater to operate. *Open only when servicing unit or for a prolonged shutdown.*
10. For 460-volt units, a transformer rated as follows may be field supplied:  
 150 va for 06DE824, E537, and 07DB215; 100 va for 06DA818 and 07DA106, A208, B210.
11. Transformer must be used and grounded in accordance with all applicable codes.
12. Liquid line solenoid valve (LLS) must be field supplied and wired in accordance with National Electrical Code (NEC). Maximum load: 50 va holding, 200 va inrush.

#### INDEX (60-Hertz)

UNIT	VOLTS	PH	FIG. NO.	DESCRIPTION	LABEL DIAG	
06D	A818 E824 E537	208/230, 460	3	1	Schematic Diagram and Component Arrangement	203
07D	A106	200,230, 460	3	1		
	A208 B210 B215	208/230, 460				
06D Compr			2	Terminal Diagrams	-	
All 06D & 07D	All	3	3	Access Elec Solenoid Unloader Wiring	-	
			4	Recommended Field Wiring	-	

#### MODEL NUMBERS

VOLTS	PHASE	MODEL
200	3	400
230		500
208/230		510
460		600

#### FIELD WIRING

All units are factory wired for single-pumpout control (with field addition of pilot duty control and liquid line solenoid valve). Wiring may be modified for automatic pumpdown control as shown in Fig. 4. See 06D,07D Installation, Start-Up and Service Instructions for further details.

→ Do not use automatic pumpdown control on dry-expansion cooler applications. For these applications, modify single-pumpout control by removing pumpout relay from the circuit.

Do not use automatic pumpdown control when compressor is equipped with cylinder head bypass unloader(s).

(Continued on page 3.)



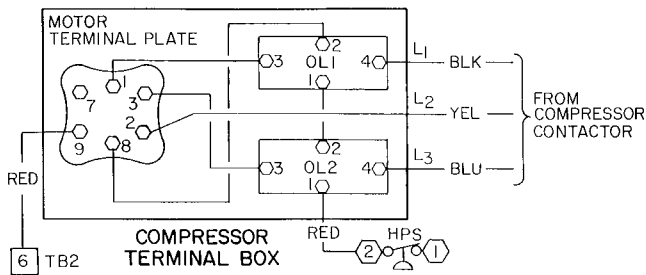
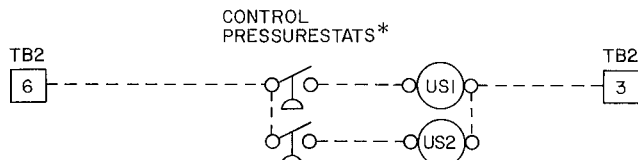

Fig. 2 – Compressor Terminal Diagram



\*Control pressurestats or thermostats are field supplied  
NOTE Solenoids unload compressor when they are energized

Fig. 3 – Accessory Electric Solenoid Unloader Wiring

LEGEND (Fig 2, 3, 4)

- Aux – Auxiliary
- C – Contactor
- CR – Control Relay
- HPS – High Pressure Switch
- LLS – Liquid Line Solenoid Valve
- LPS – Low Pressure Switch
- M<sub>3</sub> – Evaporator Fan or Chilled Water Pump
- M<sub>4</sub> – Cooling Tower Pump, Air-Cooled or Evaporative Condenser Fan
- M<sub>5</sub> – Cooling Tower Fan or Evaporative Condenser Pump
- OL – Overload Relay
- POR – Pumpout Relay
- Sw – Switch
- TB – Terminal Block
- TR – Timer Relay
- US – Compressor Unloader Solenoid
- Factory Wiring
- - - Field Wiring

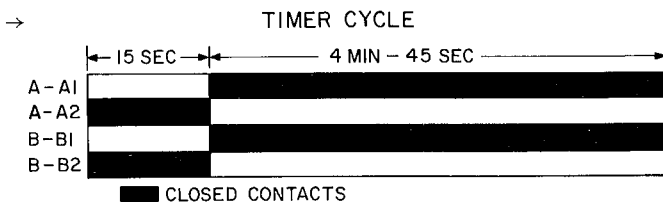

→ 13. Motor cam on Time Guard® timer rotates one revolution in 5 minutes when motor is energized (see Timer Cycle chart). Timer contacts are in A-A2 and B-B2 position for 15 seconds to provide advance start for unit auxiliaries and in A-A1 and B-B1 position for 4 minutes and 45 seconds to prevent short cycling of compressor. During normal operation of unit, timer contacts are in A-A1 and B-B1 position, with the timer motor de-energized. The Time Guard timer provides a minimum time lag of 5 minutes before compressor can restart after stopping for any reason.

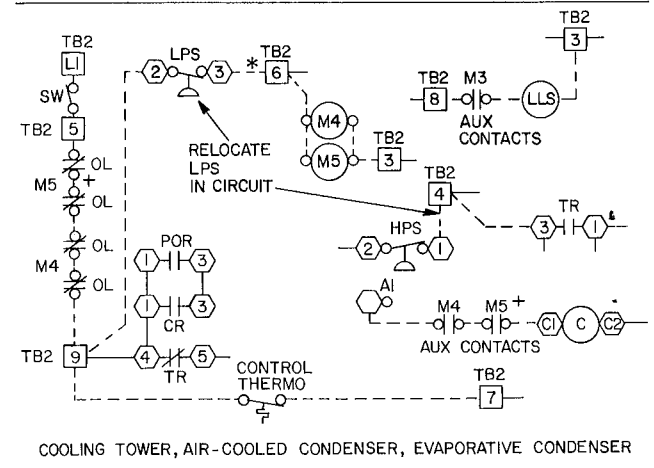
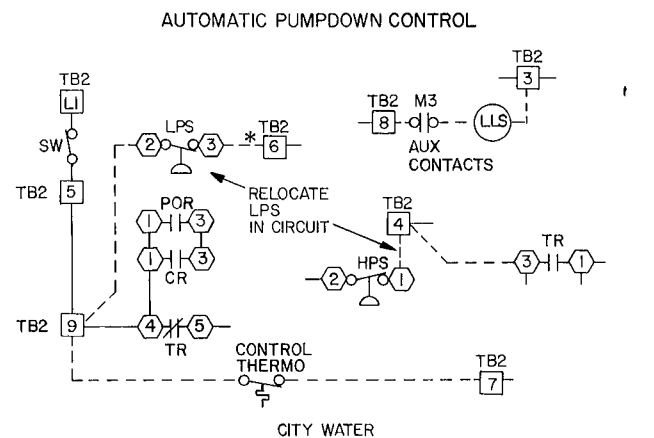
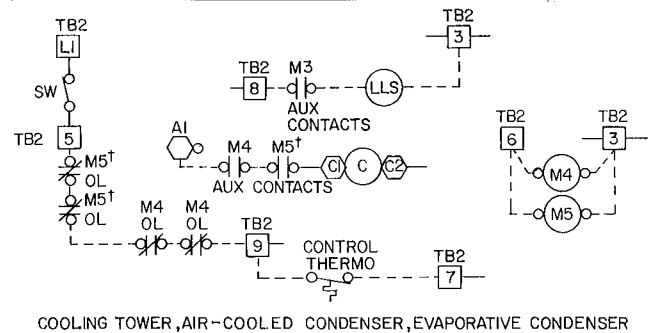
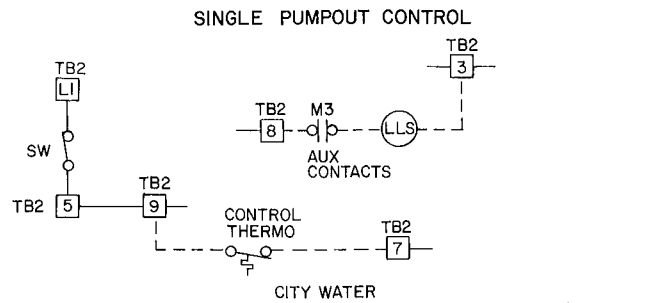

\*Disconnect wire from terminal 3 on POR normally open contacts and connect to terminal 3 on LPS  
| Optional

Fig. 4 – Recommended Field Wiring

Manufacturer reserves the right to discontinue, or change at any time, specifications or designs without notice and without incurring obligations.

Book	2
Tab	2a

Form 06D,07D-3W New

Printed in U S A

682

4-79

PC 111

Catalog No 530-635