



Product Data

06DA,DE 06EV,EW Compressor Units

5 to 40 Nominal Tons

With  06D,06E Compressors

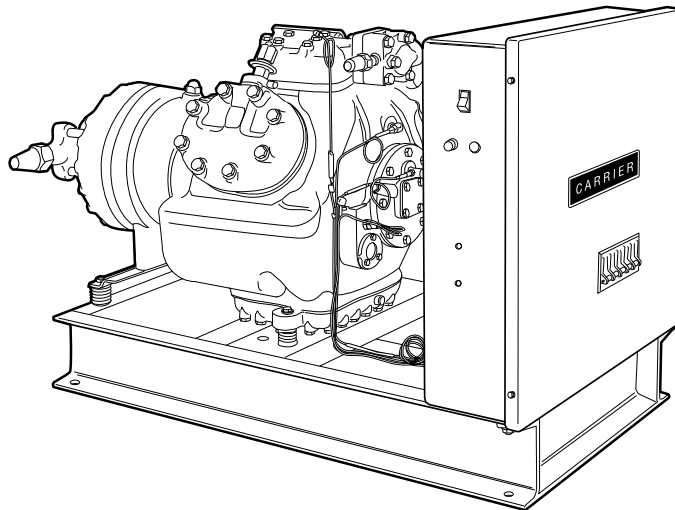

06E Compressor Unit

A quality compressor for the right application

The Carlyle line of 06D, 06E semi-hermetic compressors is designed for light, medium, or heavy duty applications from one through 40 tons. Use them with complete confidence for air conditioning or refrigeration, with either water-cooled, air-cooled, or evaporative condensers.

Features/Benefits

System dependability

Reliable trouble-free operation and long unit life is assured with this motor-compressor. This hermetically sealed unit eliminates dirt, air, and moisture contamination in the refrigeration system, and also eliminates shaft seal and alignment problems. Compressor wear is minimized by the positive pressure lubrication provided with a built-in oil pressure regulator and an automatically reversible oil pump.

Operating efficiency

Power conserving capacity control valves on Carlyle compressors provide the most efficient operation at the lowest cost. These valves automatically match the compressor capacity to system load variations.

Suction cutoff unloading further reduces energy usage during unloaded operation. Valve body shuts off passage from suction manifold, preventing charge from unnecessarily being pulled into cylinder. This results in an EER (Energy Efficiency Ratio) improvement of as much as 39.5% at 33% load.

Rely with confidence on the overall protection devices built into these fine compressors. The Time Guard® circuit prevents rapid compressor cycling. High- and low-pressure switches protect against excessive motor loads due to refrigeration system problems.

A lightweight crankcase, made of fine grain cast iron, meets all code pressure requirements. Large refrigerant gas passages guarantee low pressure losses and higher compression efficiency as well as providing for motor cooling.

Sound level is kept at a minimum with a discharge line muffler. This muffler is an accessory for the 06D and 06E compressors.

Table of contents



	Page
Features/Benefits	1
Model Number Nomenclature	2,3
Physical Data	3
Base Unit Dimensions	4
Selection Procedure	5
Performance Data	5-13
Electrical Data	14,15
Typical Piping and Wiring	16
Application Data	17
Guide Specifications	18

Model number nomenclature

→

06D A 8 18 1 A A 0 5 0 1

Product Series

06D — Base Mounted Compressor and Panel

Capacity Control

	Unloaders		
	2 Cyl	4 Cyl	6 Cyl
A —	0	1	—
E —	—	—	2
H —	—	1	—

Motor Size

	Horsepower		
	2 Cyl	4 Cyl	6 Cyl
3 —	—	5	10
5 —	—	—	15
8 —	3	6 1/2	7 1/2

Displacement Cfm

Example: 18 = 18 Cfm

- 08 (2 Cyl)
- 13 (4 Cyl)
- 18 (4 Cyl)
- 24 (6 Cyl)
- 28 (6 Cyl)
- 37 (6 Cyl)

Unit

1 — Compressor and Panel Installed on Base

Packaging

1 — Domestic

V - Ph - Hz

- 1 — 575-3-60
- 5 — 208/230-3-60
- 6 — 460-3-60

Motor Protection

A,E — External Overloads and Internal Thermostat

Suction Valve Location

Model number nomenclature

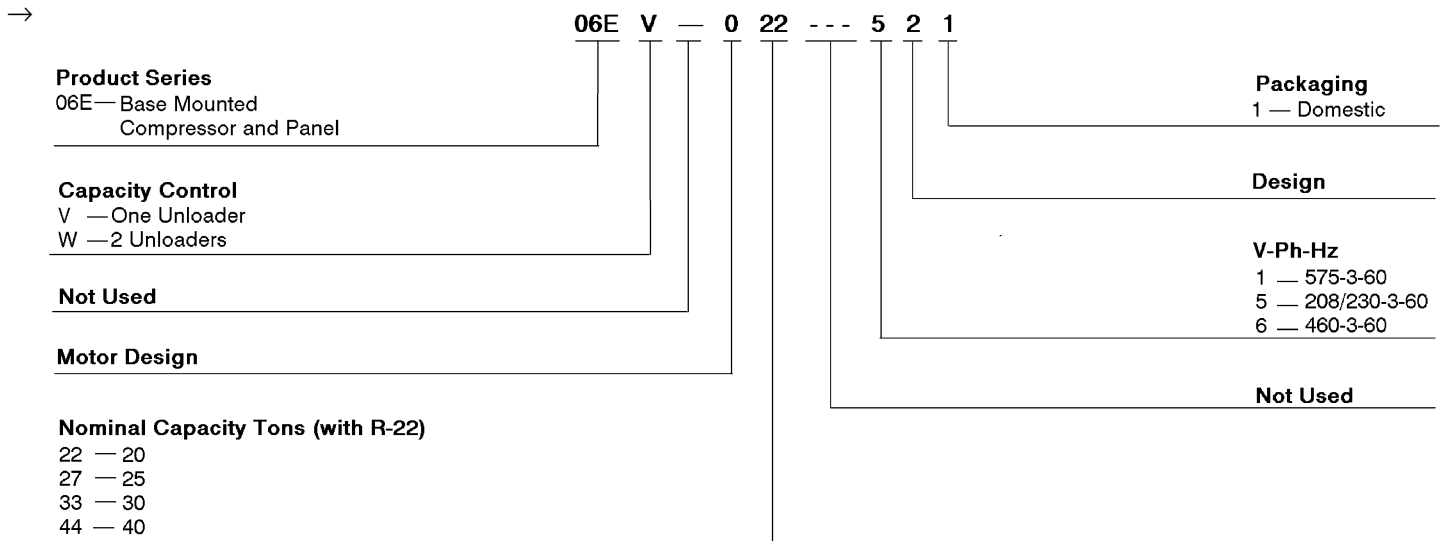

Physical data

→ **06D COMPRESSOR UNIT**

UNIT 06D	A8081	H3131	A8181	E8241	E3281	E5371
OPERATING WEIGHT — lb	220	275	290	350	350	350
REFRIGERANT	R-12, R-22, R-500, R-502 (New HFC — Contact Carrier)					
COMPRESSOR — 06D	808	313	818	824	328	537
Cylinders	2	4	4	6	6	6
Bore — in.	2	2	2	2	2	2
Stroke — in.	1¼	1	17/16	1¼	115/32	115/16
Displacement — cfm at 1750 rpm	8.0	13.1	18.3	23.9	28.0	37.1
Maximum rpm	1750	1750	1750	1750	1750	1750
Oil Charge — pt	3	4½	5½	8	8	8
High Side Maximum Pressure	450 psig					
Low Side Maximum Pressure	245 psig					
CONNECTIONS — in.						
Suction Valve — ODF	7/8	7/8	1½	1¾	1¾	1¾
Discharge Valve — ODF	5/8	5/8	7/8	7/8	1½	1½

06E COMPRESSOR UNIT

UNIT 06E	V022	W027	W033	W044
OPERATING WEIGHT — lb	600	640	650	670
REFRIGERANT	R-12, R-22, R-500, R-502			
COMPRESSOR — 06E	4250	5265	5275	5299
Cylinders	4	6	6	6
Bore — in.	211/16	211/16	211/16	211/16
Stroke — in.	23/16	2	23/16	27/8
Displacement — cfm at 1750 rpm	50	68	75	99
Maximum Rpm	1750	1750	1750	1750
Oil Charge — pt	14	19	19	19
High Side Maximum Pressure	450 psig			
Low Side Maximum Pressure	245 psig			
CONNECTIONS — in.				
Suction Valve — ODF	1½	1½	2½	2½
Discharge Valve — ODF	1½	1¾	1¾	1½

Base unit dimensions



→ 06D COMPRESSOR

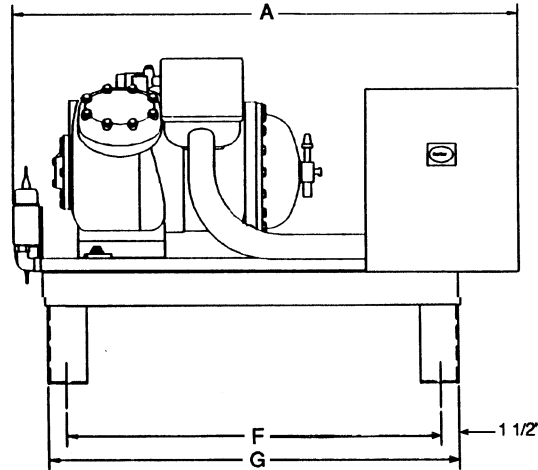
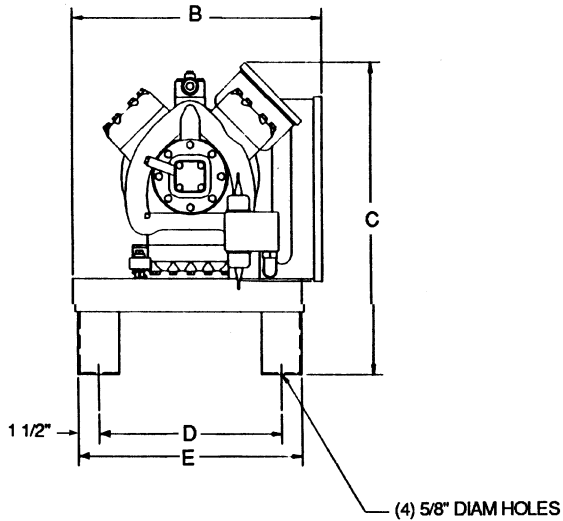
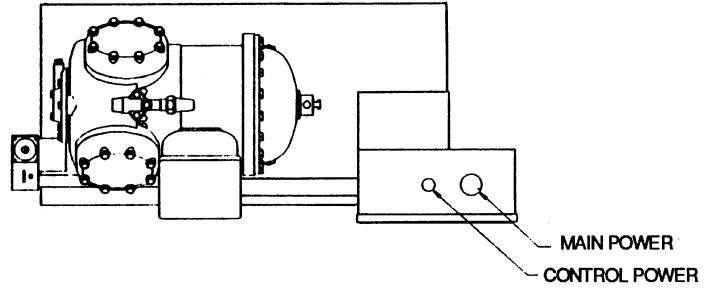

DIMENSIONS — ft-in.

06D UNIT		A8081	H3131	A8181	E8241	E3281	E5371
Length	A	3-1 ³ / ₈					
Width	B	1- 3 ⁷ / ₁₆					1-6 ¹ / ₂
Height	C	1- 6 ⁷ / ₈	1-11 ³ / ₈		1-9 ³ / ₄		
Mounting Holes	D	0-10 ¹ / ₂		1-1 ⁵ / ₈			
Mounting Holes	E	1- 1 ⁵ / ₁₆		1-4 ⁵ / ₈			
Mounting Holes	F	2-3 ⁵ / ₈					
Mounting Holes	G	2-6 ⁵ / ₈					

06E COMPRESSOR

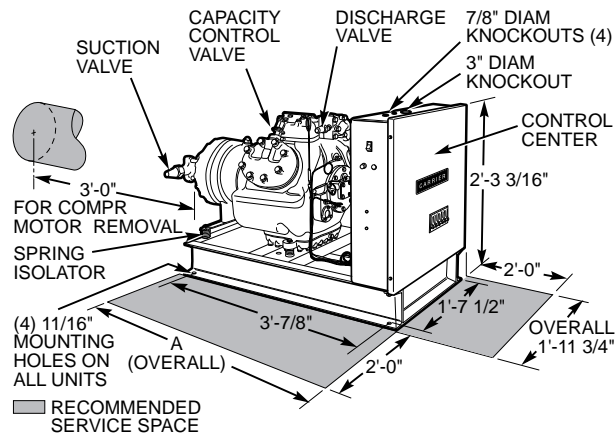

Certified dimension drawings available on request.

06D CONTROL BOX

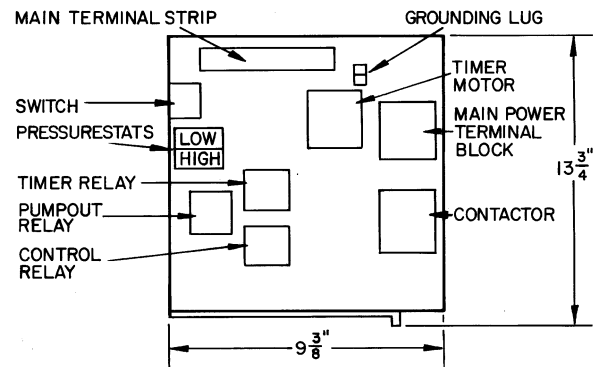

NOTE: Supplied with compressor. Overload relays and terminals for internal thermostat are located in compressor terminal box.

DIMENSIONS — ft-in.

UNIT 06E		V022	W027	W033	W044
Length	A	3-11 ³ / ₈	3-11 ³ / ₈	4-1 ¹ / ₁₆	4-1 ¹ / ₁₆

Selection procedure



I Determine refrigerant, load, saturated suction temperature, and saturated discharge temperature.

Given:

Refrigerant R-22
 Cooling Load 40 Tons
 Saturated Suction Temperature 40 F
 Saturated Discharge Temperature 105 F

II Enter Compressor Capacities table for correct refrigerant at required suction and discharge temperatures. Read across until a suitable capacity is found. Determine motor-compressor

selection, power input (kW) requirements, and total heat rejection (THR). (Use direct interpolation where job requirements fall between values shown. Do not extrapolate.)

Select an 06EW044 which has a cooling capacity of 41.7 tons at a saturated suction temperature of 40 F and saturated discharge temperature of 105 F. Motor-compressor power input is 39.4 kW and total heat rejection is 51.9 tons.

Refer to Compressor Capacities notes for information concerning basis for compressor ratings and capacity corrections due to refrigerant superheat or subcooling.

Performance data*

COMPRESSOR CAPACITIES (Tons)

R-12

SST	SDT	06DA8181			06DE8241			06DE5371		
		Cap.	kW	THR	Cap.	kW	THR	Cap.	kW	THR
-10	90	1.6	2.6	2.4	2.1	3.3	3.0	3.6	5.1	5.1
	100	1.5	2.8	2.3	1.9	3.4	2.9	3.2	4.3	4.4
	105	1.4	2.8	2.2	1.8	3.5	2.8	3.0	3.9	4.1
	110	1.3	2.9	2.2	1.7	3.5	2.7	2.9	3.5	3.9
	120	1.2	3.0	2.1	1.5	3.5	2.5	2.6	3.1	3.5
0	90	2.2	3.0	3.1	2.8	3.8	3.9	4.6	6.3	6.4
	100	2.0	3.2	3.0	2.6	3.9	3.7	4.1	5.8	5.8
	105	1.9	3.3	2.9	2.5	4.0	3.6	3.9	5.6	5.5
	110	1.8	3.4	2.8	2.3	4.1	3.5	3.7	5.4	5.3
	120	1.7	3.5	2.7	2.1	4.2	3.3	3.4	5.1	4.9
10	130	1.4	3.6	2.5	1.8	4.2	3.1	3.1	5.2	4.6
	90	2.9	3.3	3.9	3.7	4.2	4.9	5.8	7.1	7.9
	100	2.7	3.5	3.7	3.4	4.4	4.7	5.2	6.9	7.2
	105	2.6	3.6	3.6	3.2	4.5	4.5	5.0	6.8	7.0
	110	2.5	3.8	3.6	3.1	4.6	4.4	4.8	6.8	6.7
20	120	2.2	4.0	3.4	2.8	4.7	4.2	4.5	6.7	6.4
	130	2.0	4.1	3.2	2.5	4.9	3.9	4.1	6.8	6.1
	140	1.7	4.2	2.9	2.2	5.0	3.6	3.7	7.4	5.8
	145	1.5	4.2	2.7	2.0	5.1	3.5	3.4	7.8	5.6
	30	90	3.7	3.5	4.8	4.7	4.5	6.0	7.4	7.6
100		3.5	3.8	4.6	4.4	4.8	5.7	6.7	7.8	8.9
105		3.3	4.0	4.5	4.2	5.0	5.6	6.4	7.8	8.6
110		3.2	4.1	4.4	4.0	5.1	5.5	6.1	7.8	8.4
120		2.9	4.4	4.2	3.7	5.3	5.2	5.7	7.9	8.0
40	130	2.6	4.6	3.9	3.3	5.5	4.9	5.3	8.2	7.6
	140	2.3	4.7	3.6	3.0	5.7	4.6	4.8	8.7	7.2
	145	2.1	4.7	3.4	2.8	5.8	4.4	4.5	9.1	7.0
	90	4.7	3.7	5.8	6.0	4.8	7.4	9.4	7.9	11.7
	100	4.4	4.1	5.6	5.5	5.2	7.0	8.5	8.4	10.9
50	105	4.2	4.3	5.5	5.3	5.4	8.1	8.1	8.6	10.6
	110	4.1	4.4	5.3	5.1	5.5	6.7	7.8	8.8	10.3
	120	3.7	4.8	5.1	4.6	5.8	6.3	7.2	9.0	9.8
	130	3.3	5.0	4.8	4.2	6.1	6.0	6.7	9.3	9.3
	140	2.9	5.2	4.4	3.8	6.4	5.7	6.1	9.8	8.9
60	145	2.7	5.2	4.2	3.6	6.5	5.5	5.7	10.1	8.6
	90	5.9	3.8	7.0	7.5	4.9	8.9	11.8	8.3	14.1
	100	5.5	4.2	6.7	6.9	5.5	8.4	10.7	9.2	13.3
	105	5.3	4.5	6.6	6.6	5.7	8.2	10.2	9.5	12.9
	110	5.1	4.7	6.4	6.3	5.9	8.0	9.8	9.7	12.5
70	120	4.6	5.1	6.1	5.8	6.3	7.6	9.1	10.1	12.0
	130	4.2	5.4	5.8	5.3	6.7	7.2	8.4	10.4	11.4
	140	3.7	5.7	5.3	4.8	7.1	6.8	7.7	10.9	10.8
	145	3.5	5.7	5.1	4.6	7.3	6.6	7.3	11.2	10.5
	80	90	7.3	3.7	8.4	9.3	5.0	10.7	14.7	8.9
100		6.8	4.3	8.0	8.5	5.6	10.1	13.3	10.1	16.2
105		6.5	4.6	7.8	8.1	5.9	9.8	12.7	10.5	15.7
110		6.2	4.8	7.6	7.8	6.2	9.6	12.2	10.8	15.3
120		5.7	5.3	7.3	7.2	6.7	9.1	11.3	11.3	14.5
90	130	5.2	5.8	6.9	6.6	7.2	8.7	10.5	11.7	13.8
	140	4.7	6.1	6.4	6.0	7.7	8.2	9.6	12.1	13.0
	145	4.4	6.2	6.1	5.7	8.0	8.0	9.1	12.3	12.7

LEGEND

Cap. — Capacity (tons) SST — Saturated Suction Temperature (F)
 kW — Power Input THR — Total Heat Rejection (tons)
 SDT — Saturated Discharge Temperature (F)

→ *For data on sizes 06DA8081, 06DAH3131, and 06DAE3281, contact Carrier.

Performance data (cont)



COMPRESSOR CAPACITIES (Tons)

R-12

SST	SDT	06EV022			06EW027			06EW033			06EW044		
		Cap.	kW	THR	Cap.	kW	THR	Cap.	kW	THR	Cap.	kW	THR
-10	90	—	—	—	4.3	7.8	6.4	6.3	9.6	8.8	8.3	13.3	11.7
	100	—	—	—	—	—	—	5.7	9.8	8.2	7.5	13.7	11.0
	105	—	—	—	—	—	—	5.4	9.9	7.9	—	—	—
0	90	5.6	8.6	7.8	6.8	9.9	9.4	8.5	10.9	11.3	11.1	15.3	15.0
	100	5.0	8.8	7.3	5.7	9.5	8.2	7.7	11.4	10.6	10.1	15.9	14.2
	105	4.8	8.9	7.1	5.1	9.2	7.5	7.3	11.6	10.3	9.6	16.2	13.8
	110	—	—	—	4.5	8.7	6.7	7.0	11.7	10.0	9.2	16.5	13.4
	120	—	—	—	—	—	—	6.3	12.0	9.4	—	—	—
10	90	7.4	9.5	9.8	9.6	11.5	12.6	11.1	12.2	14.3	14.5	17.2	18.9
	100	6.7	9.8	9.3	8.4	11.6	11.5	10.2	12.9	13.5	13.3	18.1	18.0
	105	6.4	10.0	9.0	7.8	11.6	10.8	9.7	13.2	13.1	12.7	18.6	17.5
	110	6.1	10.1	8.7	7.2	11.4	10.2	9.3	13.4	12.8	12.2	19.0	17.1
	120	5.5	10.3	8.2	5.9	10.8	8.7	8.4	13.9	12.0	11.1	19.7	16.2
	130	—	—	—	—	—	—	7.6	14.2	11.3	10.0	20.3	15.3
20	90	9.6	10.2	12.2	12.7	12.7	16.0	14.3	13.4	17.8	18.6	19.0	23.6
	100	8.8	10.7	11.6	11.5	13.3	15.0	13.2	14.3	16.9	17.2	20.3	22.4
	105	8.4	11.0	11.2	10.9	13.5	14.4	12.6	14.7	16.5	16.5	20.8	21.9
	110	8.0	11.2	10.9	10.2	13.6	13.8	12.1	15.1	16.0	15.8	21.4	21.3
	120	7.3	11.6	10.3	8.9	13.6	12.4	11.0	15.8	15.1	14.5	22.4	20.3
	130	6.6	11.8	9.6	7.5	13.1	10.9	10.0	16.3	14.3	13.2	23.3	19.2
	140	5.9	12.0	9.0	6.0	12.2	9.1	9.1	16.8	13.4	11.9	24.1	18.2
30	90	12.3	10.7	15.0	16.2	13.3	19.6	18.2	14.3	21.9	23.6	20.7	29.0
	100	11.3	11.5	14.3	14.9	14.5	18.7	16.8	15.5	20.9	21.9	22.2	27.6
	105	10.8	11.8	13.9	14.3	14.9	18.2	16.2	16.1	20.3	21.0	23.0	27.0
	110	10.4	12.2	13.5	13.6	15.3	17.6	15.5	16.6	19.8	20.2	23.7	26.3
	120	9.5	12.7	12.8	12.2	15.9	16.3	14.2	17.5	18.8	18.6	25.1	25.1
	130	8.6	13.2	12.0	10.8	16.0	14.9	13.0	18.4	17.8	17.0	26.3	23.8
	140	7.8	13.6	11.3	9.2	15.7	13.3	11.8	19.1	16.8	15.5	27.4	22.6
40	90	15.4	11.0	18.3	20.1	13.5	23.6	22.8	14.9	26.7	29.5	22.0	35.2
	100	14.3	12.0	17.4	18.8	15.1	22.7	21.2	16.4	25.4	27.5	24.0	33.7
	105	13.7	12.5	16.9	18.1	15.8	22.2	20.4	17.2	24.8	26.4	25.0	32.9
	110	13.1	12.9	16.5	17.4	16.5	21.7	19.6	17.8	24.2	25.5	25.9	32.1
	120	12.1	13.7	15.6	15.9	17.6	20.5	18.1	19.1	23.0	23.5	27.6	30.6
	130	11.0	14.4	14.8	14.4	18.3	19.1	16.6	20.3	21.8	21.6	29.2	29.2
	140	10.0	15.0	13.9	12.8	18.7	17.6	15.2	21.3	20.7	19.8	30.6	27.7
50	90	19.2	10.9	22.0	24.6	13.0	28.0	28.2	15.0	32.1	36.5	23.1	42.5
	100	17.8	12.2	21.0	23.2	15.1	27.1	26.3	17.0	30.7	34.0	25.5	40.6
	105	17.1	12.9	20.4	22.4	16.1	26.6	25.4	17.9	30.0	32.8	26.6	39.7
	110	16.5	13.4	19.9	21.7	17.0	26.1	24.4	18.8	29.3	31.7	27.7	38.8
	120	15.2	14.5	18.9	20.1	18.7	24.9	22.6	20.5	27.9	29.3	29.9	37.1
	130	13.9	15.5	18.0	18.5	20.0	23.6	20.8	22.0	26.5	27.1	31.9	35.4
	140	12.8	16.3	17.0	16.7	21.0	22.2	19.1	23.3	25.2	24.9	33.7	33.7

Cap. — Capacity (tons)
kW — Power Input
SDT — Saturated Discharge Temperature (F)
SST — Saturated Suction Temperature (F)
THR — Total Heat Rejection (tons)



COMPRESSOR CAPACITIES (Tons)

R-22

SST	SDT	06DA8181			06DE8241			06DE5371		
		Cap.	kW	THR	Cap.	kW	THR	Cap.	kW	THR
-10	90	2.6	4.1	3.7	3.3	5.2	4.8	5.0	8.5	7.4
	100	2.3	4.2	3.5	3.0	5.4	4.5	4.4	8.7	6.9
	105	2.2	4.2	3.4	2.8	5.4	4.4	4.2	8.8	6.7
	110	2.1	4.3	3.4	2.6	5.5	4.2	3.9	8.9	6.4
	120	1.9	4.4	3.1	2.2	5.6	3.8	3.3	8.9	5.9
0	90	3.4	4.6	4.8	4.4	5.9	6.0	6.8	9.3	9.5
	100	3.2	4.7	4.5	4.0	6.1	5.8	6.2	9.8	9.0
	105	3.0	4.8	4.4	3.8	6.2	5.6	5.9	10.0	8.7
	110	2.9	4.9	4.3	3.6	6.4	5.4	5.5	10.2	8.4
	120	2.6	5.1	4.1	3.2	6.5	5.1	4.8	10.5	7.8
	130	2.4	5.3	3.9	2.8	6.7	4.7	4.2	10.6	7.2
	140	2.1	5.4	3.6	2.4	6.8	4.4	3.9	10.5	6.9
10	90	4.5	5.0	6.0	5.7	6.5	7.5	9.0	10.2	11.9
	100	4.2	5.3	5.7	5.3	6.8	7.2	8.3	10.9	11.4
	105	4.0	5.4	5.6	5.0	7.0	7.0	7.9	11.2	11.1
	110	3.8	5.6	5.4	4.8	7.2	6.8	7.5	11.5	10.8
	120	3.5	5.9	5.2	4.3	7.5	6.4	6.7	12.0	10.2
	130	3.2	6.1	5.0	3.8	7.7	6.1	6.0	12.4	9.5
	140	2.9	6.3	4.7	3.5	7.9	5.7	5.6	12.5	9.2
	145	2.7	6.4	4.5	3.3	8.0	5.6	5.2	12.6	8.8
20	90	5.8	5.3	7.4	7.3	7.0	9.3	11.5	11.1	14.7
	100	5.4	5.7	7.0	6.8	7.5	8.9	10.8	12.0	14.2
	105	5.2	5.9	6.9	6.5	7.7	8.7	10.4	12.4	13.9
	110	5.0	6.1	6.7	6.2	7.9	8.5	9.9	12.8	13.5
	120	4.6	6.5	6.4	5.6	8.4	8.0	9.0	13.5	12.9
	130	4.2	6.9	6.2	5.1	8.8	7.6	8.1	14.1	12.1
	140	3.8	7.2	5.9	4.6	9.1	7.2	7.6	14.5	11.7
	145	3.6	7.4	5.7	4.4	9.3	7.1	7.1	14.8	11.3
30	90	7.4	5.6	9.1	9.2	7.3	11.3	14.4	11.9	17.8
	100	6.9	6.0	8.6	8.6	8.0	10.8	13.5	12.9	17.3
	105	6.6	6.3	8.4	8.2	8.3	10.6	13.1	13.4	16.9
	110	6.3	6.5	8.2	7.9	8.6	10.4	12.6	13.9	16.6
	120	5.8	7.1	7.8	7.2	9.2	9.9	11.6	14.9	15.8
	130	5.3	7.6	7.5	6.6	9.7	9.4	10.5	15.7	15.0
	140	4.9	8.0	7.2	6.0	10.2	9.0	10.0	16.0	14.6
	145	4.6	8.2	7.0	5.8	10.5	8.8	9.1	16.6	13.8
40	90	9.3	5.7	11.0	11.5	7.4	13.6	17.6	12.6	21.2
	100	8.6	6.3	10.4	10.7	8.3	13.0	16.7	13.8	20.6
	105	8.3	6.6	10.2	10.3	8.7	12.8	16.1	14.4	20.2
	110	7.9	6.9	9.9	9.9	9.1	12.5	15.6	15.0	20.0
	120	7.3	7.5	9.5	9.1	9.9	11.9	14.4	16.1	19.0
	130	6.7	8.2	9.0	8.3	10.6	11.4	13.2	17.2	18.1
	140	6.1	8.8	8.6	7.7	11.3	10.9	12.6	17.6	17.6
	145	5.8	9.0	8.4	7.4	11.6	10.7	11.5	18.3	16.7
50	90	11.6	5.7	13.2	14.1	7.4	16.2	21.1	13.2	24.8
	100	10.7	6.3	12.5	13.2	8.4	15.6	20.0	14.5	24.0
	105	10.3	6.7	12.2	12.7	8.9	15.3	19.4	15.1	23.8
	110	9.9	7.1	11.9	12.2	9.5	15.0	18.0	15.8	23.3
	120	9.1	7.8	11.4	11.3	10.5	14.3	17.5	17.1	22.4
	130	8.4	8.6	10.8	10.4	11.4	13.7	16.2	18.4	21.4
	140	7.6	9.4	10.3	9.6	12.3	13.1	15.0	19.0	20.4
	145	7.3	9.7	10.1	9.2	12.7	12.9	14.3	19.7	18.4

- Cap.** — Capacity (tons)
- kW** — Power Input
- SDT** — Saturated Discharge Temperature (F)
- SST** — Saturated Suction Temperature (F)
- THR** — Total Heat Rejection (tons)

NOTE: To ensure proper cooling, it is required that all 6-cylinder compressors operating with R-22 at 20 F SST or below have one of the 2 unloaders disconnected.

Performance data (cont)



COMPRESSOR CAPACITIES (Tons)

R-22

SST	SDT	06EV022			06EW027			06EW033			06EW044		
		Cap.	kW	THR	Cap.	kW	THR	Cap.	kW	THR	Cap.	kW	THR
-10	90	6.4	10.8	9.2	6.9	11.3	9.8	9.8	14.7	13.6	12.9	20.8	18.3
	100	5.8	10.9	8.6	5.2	9.9	7.7	8.9	15.1	12.8	11.8	21.5	17.3
	105	5.5	11.0	8.3	4.3	9.0	6.6	8.5	15.2	12.4	11.2	21.8	16.9
0	90	8.7	12.2	11.9	10.7	14.6	14.5	13.2	16.8	17.6	17.3	24.0	23.5
	100	7.9	12.6	11.2	9.0	14.1	12.7	12.1	17.5	16.6	15.8	25.1	22.3
	105	7.5	12.7	10.8	8.1	13.6	11.6	11.5	17.8	16.1	15.1	25.6	21.7
	110	7.1	12.8	10.5	7.2	12.9	10.5	11.0	18.1	15.7	14.4	26.0	21.2
	120	6.4	13.0	9.8	5.2	10.9	8.0	9.9	18.5	14.7	13.1	26.7	20.0
10	90	11.5	13.6	15.1	15.0	17.1	19.4	17.4	18.9	22.3	22.6	27.1	29.6
	100	10.6	14.2	14.2	13.3	17.4	17.8	16.0	19.9	21.1	20.9	28.6	28.3
	105	10.1	14.4	13.8	12.4	17.3	16.9	15.3	20.4	20.6	20.0	29.3	27.6
	110	9.6	14.6	13.4	11.5	17.1	15.9	14.6	20.8	20.0	19.1	29.9	26.9
	120	8.7	15.0	12.6	9.5	16.2	13.7	13.3	21.6	18.9	17.5	31.1	25.5
	130	7.8	15.2	11.8	7.4	14.5	11.1	12.1	22.1	17.8	15.9	32.1	24.2
20	90	15.0	14.7	18.8	19.9	18.9	24.8	22.4	20.7	27.8	29.2	30.0	36.9
	100	13.8	15.6	17.8	18.1	20.0	23.3	20.7	22.1	26.5	27.0	32.0	35.3
	105	13.2	16.0	17.4	17.2	20.4	22.4	19.9	22.8	25.8	25.9	32.9	34.4
	110	12.5	16.4	16.8	16.2	20.6	21.5	19.1	23.4	25.1	24.9	33.8	33.6
	120	11.5	17.0	15.9	14.2	20.6	19.5	17.5	24.5	23.8	22.9	35.4	32.0
	130	10.4	17.4	15.0	12.0	19.9	17.2	15.9	25.5	22.5	20.9	36.8	30.4
	140	9.4	17.8	14.0	9.7	18.5	14.5	14.5	26.2	21.2	19.0	38.1	28.9
30	90	19.2	15.5	23.2	25.4	20.0	30.5	28.5	22.1	34.3	37.0	32.6	45.4
	100	17.7	16.8	22.1	23.5	21.8	29.1	26.5	24.0	32.7	34.4	35.1	43.5
	105	17.0	17.3	21.5	22.5	22.6	28.4	25.5	24.9	31.9	33.1	36.3	42.5
	110	16.3	17.9	20.9	21.5	23.2	27.5	24.5	25.8	31.1	31.8	37.5	41.5
	120	15.0	18.8	19.8	19.4	24.1	25.6	22.5	27.3	29.6	29.4	39.6	39.6
	130	13.6	19.6	18.7	17.2	24.4	23.5	20.6	28.7	28.1	27.0	41.6	37.7
	140	12.4	20.2	17.6	14.8	24.1	21.0	18.8	29.9	26.5	24.7	43.3	35.9
	40	90	24.2	15.9	28.3	31.6	20.2	36.8	35.8	23.0	41.8	46.4	34.7
100		22.5	17.6	27.0	29.6	22.8	35.5	33.3	25.5	39.9	43.2	37.9	53.0
105		21.6	18.4	26.4	28.6	23.9	34.8	32.1	26.7	39.0	41.7	39.4	51.9
110		20.8	19.1	25.7	27.5	25.0	34.0	30.9	27.8	38.1	40.2	40.8	50.7
120		19.1	20.4	24.4	25.2	26.8	32.2	28.6	29.8	36.3	37.2	43.6	48.5
130		17.5	21.5	23.1	22.9	28.0	30.1	26.3	31.7	34.5	34.3	46.1	46.2
140		16.0	22.5	21.8	20.4	28.7	27.8	24.1	33.3	32.7	31.5	48.5	44.0
50	90	30.2	15.7	34.2	38.7	19.4	43.7	44.5	23.2	50.5	57.5	36.3	66.9
	100	28.1	17.9	32.7	36.5	22.8	42.4	41.5	26.4	48.3	53.7	40.2	64.1
	105	27.0	18.9	31.9	35.4	24.3	41.7	40.0	27.8	47.2	51.8	42.0	62.7
	110	26.0	19.9	31.2	34.2	25.8	40.9	38.6	29.3	46.2	50.0	43.8	61.4
	120	24.0	21.6	29.6	31.8	28.5	39.2	35.8	31.9	44.0	46.4	47.2	58.7
	130	22.1	23.2	28.1	29.3	30.6	37.2	33.1	34.3	41.9	43.0	50.4	56.0
	140	20.3	24.5	26.6	26.6	32.3	35.0	30.4	36.5	39.8	39.6	53.4	53.4

- Cap. — Capacity (tons)
- kW — Power Input
- SDT — Saturated Discharge Temperature (F)
- SST — Saturated Suction Temperature (F)
- THR — Total Heat Rejection (tons)

NOTE: To ensure proper cooling, it is required that all 6-cylinder compressors operating with R-22 at 20 F SST or below have one of the 2 unloaders disconnected.



COMPRESSOR CAPACITIES (Tons)

R-500

SST	SDT	06DA8181			06DE8241			06DE5371		
		Cap.	kW	THR	Cap.	kW	THR	Cap.	kW	THR
-10	90	2.1	3.2	3.0	2.4	3.7	3.4	4.0	5.6	5.6
	100	1.9	3.3	2.9	2.1	3.8	3.2	3.7	5.8	5.4
	105	1.9	3.4	2.8	2.0	3.9	3.2	3.5	5.8	5.2
	110	1.8	3.4	2.8	1.9	3.9	3.1	3.3	5.8	5.0
	120	1.6	3.5	2.6	1.8	3.9	2.9	2.8	5.8	4.5
0	90	2.8	3.5	3.8	3.2	4.3	4.5	5.4	6.7	7.3
	100	2.6	3.7	3.7	3.0	4.4	4.2	5.0	7.0	7.0
	105	2.5	3.8	3.6	2.8	4.5	4.1	4.8	7.1	6.8
	110	2.4	3.9	3.5	2.7	4.6	4.0	4.5	7.1	6.6
	120	2.1	4.0	3.3	2.4	4.7	3.8	4.0	7.2	6.1
	130	1.9	4.1	3.1	2.2	4.8	3.6	3.5	7.2	5.6
10	90	3.6	3.8	4.7	4.3	4.8	5.7	6.9	7.6	9.1
	100	3.3	4.1	4.5	3.9	5.0	5.4	6.5	8.0	8.7
	105	3.2	4.2	4.4	3.8	5.1	5.2	6.2	8.2	8.5
	110	3.0	4.3	4.3	3.6	5.2	5.1	5.9	8.3	8.3
	120	2.8	4.5	4.1	3.3	5.4	4.8	5.3	8.4	7.8
	130	2.5	4.7	3.9	2.9	5.6	4.5	4.8	8.5	7.2
	140	2.3	4.8	3.6	2.7	5.8	4.3	4.2	8.6	6.7
	145	2.1	4.9	3.5	2.5	5.9	4.2	4.0	8.6	6.5
20	90	4.5	4.1	5.7	5.5	5.2	7.0	8.9	8.4	11.3
	100	4.2	4.4	5.4	5.1	5.5	6.7	8.2	8.9	10.8
	105	4.0	4.6	5.3	4.9	5.7	6.5	7.9	9.1	10.5
	110	3.9	4.7	5.2	4.7	5.8	6.3	7.6	9.3	10.2
	120	3.5	5.0	5.0	4.2	6.1	6.0	6.9	9.6	9.6
	130	3.2	5.2	4.7	3.8	6.4	5.7	6.2	9.9	9.0
	140	2.9	5.4	4.5	3.5	6.6	5.3	5.6	10.1	8.5
	145	2.8	5.5	4.4	3.3	6.7	5.2	5.3	10.1	8.2
30	90	5.6	4.3	6.8	7.0	5.4	8.6	11.2	9.0	13.8
	100	5.2	4.7	6.6	6.5	5.9	8.2	10.4	9.7	13.1
	105	5.0	4.9	6.4	6.2	6.1	8.0	9.9	10.0	12.8
	110	4.8	5.1	6.3	5.9	6.3	7.8	9.5	10.2	12.4
	120	4.4	5.4	6.0	5.4	6.7	7.3	8.6	10.7	11.7
	130	4.1	5.7	5.7	4.9	7.0	6.9	7.8	11.1	11.0
	140	3.7	6.0	5.4	4.4	7.4	6.5	7.1	11.5	10.4
	145	3.6	6.1	5.3	4.2	7.5	6.3	6.7	11.7	10.1
40	90	6.9	4.4	8.2	8.8	5.6	10.4	14.0	9.4	16.7
	100	6.4	4.9	7.8	8.1	6.2	9.9	12.9	10.3	15.8
	105	6.2	5.1	7.7	7.8	6.5	9.6	12.4	10.7	15.4
	110	5.9	5.4	7.5	7.5	6.7	9.4	11.8	11.0	15.0
	120	5.5	5.8	7.2	6.8	7.2	8.9	10.8	11.7	14.1
	130	5.1	6.1	6.8	6.2	7.6	8.4	9.8	12.3	13.3
	140	4.7	6.5	6.5	5.6	8.1	7.9	8.8	12.9	12.5
	145	—	—	—	5.3	8.3	7.7	8.4	13.2	12.2
50	90	8.5	4.3	9.7	10.9	5.6	12.5	17.3	9.6	20.0
	100	7.9	4.9	9.3	10.1	6.3	11.9	15.9	10.7	19.0
	105	7.6	5.2	9.1	9.7	6.6	11.6	15.3	11.3	18.5
	110	7.3	5.5	8.9	9.3	7.0	11.3	14.7	11.8	17.9
	120	6.8	6.0	8.5	8.5	7.6	10.6	13.3	12.7	16.9
	130	6.3	6.5	8.2	7.8	8.1	10.1	12.0	13.5	15.9
	140	—	—	—	7.0	8.6	9.5	10.9	14.3	15.0
	145	—	—	—	6.7	8.9	9.2	10.4	14.7	14.5

Cap. — Capacity (tons)
kW — Power Input
SDT — Saturated Discharge Temperature (F)
SST — Saturated Suction Temperature (F)
THR — Total Heat Rejection (tons)

Performance data (cont)



COMPRESSOR CAPACITIES (Tons)

R-500

SST	SDT	06EV022			06EW027			06EW033			06EW044		
		Cap.	kW	THR	Cap.	kW	THR	Cap.	kW	THR	Cap.	kW	THR
-10	90	4.8	8.6	7.0	5.0	8.7	7.3	7.4	11.0	10.2	9.7	15.4	13.7
	100	—	—	—	—	—	—	6.6	11.3	9.6	8.8	15.9	12.9
	105	—	—	—	—	—	—	6.3	11.4	9.2	—	—	—
0	90	6.5	9.6	9.0	8.0	11.2	10.9	9.9	12.6	13.2	13.0	17.8	17.6
	100	5.9	9.9	8.5	6.6	10.7	9.4	9.0	13.1	12.4	11.8	18.5	16.6
	105	5.6	10.0	8.2	5.9	10.3	8.6	8.6	13.3	12.0	11.3	18.9	16.2
	110	5.3	10.1	7.9	5.2	9.7	7.7	8.1	13.5	11.6	10.7	19.2	15.7
	120	—	—	—	—	—	—	7.3	13.8	10.9	—	—	—
10	90	8.7	10.6	11.4	11.2	13.1	14.6	13.0	14.2	16.7	17.0	20.1	22.2
	100	7.9	11.1	10.7	9.9	13.3	13.3	11.9	14.9	15.8	15.6	21.2	21.1
	105	7.5	11.3	10.4	9.1	13.2	12.6	11.4	15.3	15.3	14.9	21.7	20.5
	110	7.1	11.4	10.1	8.4	13.0	11.8	10.9	15.6	14.9	14.2	22.1	20.0
	120	6.4	11.6	9.4	6.8	12.2	10.0	9.8	16.1	14.0	12.9	23.0	18.9
	130	—	—	—	—	—	—	8.8	16.5	13.1	11.7	23.7	17.8
20	90	11.3	11.5	14.2	14.9	14.5	18.6	16.8	15.5	20.8	21.9	22.2	27.6
	100	10.3	12.2	13.5	13.5	15.2	17.4	15.5	16.6	19.8	20.2	23.7	26.3
	105	9.8	12.4	13.1	12.7	15.5	16.7	14.8	17.1	19.2	19.3	24.4	25.6
	110	9.4	12.7	12.7	12.0	15.6	16.0	14.2	17.5	18.7	18.5	25.0	25.0
	120	8.5	13.1	11.9	10.4	15.5	14.4	12.9	18.3	17.7	16.9	26.2	23.7
	130	7.7	13.5	11.1	8.7	15.0	12.5	11.7	19.0	16.6	15.4	27.2	22.4
	140	6.9	13.7	10.4	6.9	13.7	10.4	10.5	19.5	15.6	13.9	28.1	21.2
30	90	14.4	12.1	17.5	19.0	15.3	23.0	21.4	16.6	25.7	27.8	24.2	34.0
	100	13.2	13.1	16.6	17.5	16.7	21.8	19.8	18.0	24.4	25.7	26.1	32.4
	105	12.7	13.5	16.2	16.8	17.2	21.2	19.0	18.7	23.8	24.7	26.9	31.6
	110	12.1	13.9	15.7	16.0	17.7	20.5	18.2	19.3	23.2	23.7	27.8	30.9
	120	11.1	14.5	14.8	14.3	18.3	19.0	16.7	20.4	21.9	21.7	29.4	29.3
	130	10.0	15.1	13.9	12.5	18.4	17.3	15.2	21.4	20.7	19.9	30.8	27.8
	140	9.0	15.5	13.1	10.7	18.0	15.3	13.8	22.3	19.5	18.0	32.1	26.3
	40	90	18.1	12.5	21.4	23.7	15.5	27.7	26.8	17.3	31.3	34.7	25.8
100		16.8	13.7	20.3	22.1	17.4	26.6	24.9	19.2	29.8	32.3	28.2	39.5
105		16.1	14.3	19.8	21.3	18.3	26.0	23.9	20.0	29.1	31.0	29.3	38.6
110		15.4	14.8	19.2	20.4	19.0	25.4	23.0	20.8	28.4	29.9	30.3	37.7
120		14.1	15.7	18.2	18.7	20.3	23.9	21.2	22.3	26.9	27.5	32.4	35.9
130		12.9	16.6	17.2	16.8	21.2	22.3	19.4	23.7	25.5	25.3	34.2	34.1
140		11.7	17.2	16.2	14.9	21.6	20.4	17.7	24.9	24.1	23.1	36.0	32.4
50	90	22.6	12.3	25.7	29.0	15.0	32.8	33.2	17.5	37.8	43.0	27.1	50.0
	100	20.9	14.0	24.5	27.3	17.5	31.8	30.9	19.8	36.1	40.0	29.9	47.8
	105	20.1	14.7	23.9	26.4	18.6	31.2	29.8	20.9	35.2	38.6	31.3	46.7
	110	19.3	15.4	23.3	25.5	19.7	30.6	28.7	22.0	34.4	37.2	32.6	45.6
	120	17.8	16.7	22.1	23.6	21.7	29.2	26.5	23.9	32.7	34.4	35.1	43.5
	130	16.3	17.8	20.9	21.6	23.2	27.6	24.4	25.7	31.0	31.7	37.5	41.4
	140	14.9	18.8	19.7	19.5	24.4	25.8	22.3	27.3	29.4	29.1	39.7	39.4

Cap. — Capacity (tons)
kW — Power Input
SDT — Saturated Discharge Temperature (F)
SST — Saturated Suction Temperature (F)
THR — Total Heat Rejection (tons)



COMPRESSOR CAPACITIES (Tons)

R-502

SST	SDT	06DA8181			06DE8241			06DE5371		
		Cap.	kW	THR	Cap.	kW	THR	Cap.	kW	THR
-30	90	1.6	3.2	2.5	2.0	4.2	3.1	3.2	6.8	5.1
	100	1.4	3.3	2.3	1.8	4.3	2.9	2.8	6.7	4.7
	105	1.2	3.2	2.1	1.6	4.2	2.7	2.5	6.3	4.3
	110	1.1	3.2	2.0	1.5	4.2	2.6	2.4	6.0	4.0
-20	90	2.2	3.8	3.2	2.8	5.0	4.2	4.4	8.2	6.7
	100	1.9	4.0	2.9	2.5	5.2	4.0	3.9	8.2	6.2
	105	1.8	3.9	2.8	2.4	5.1	3.8	3.7	8.0	6.0
	110	1.7	3.9	2.7	2.2	5.1	3.6	3.4	7.8	5.6
	120	1.5	3.9	2.5	1.9	5.0	3.2	2.9	7.5	5.0
-10	90	2.9	4.4	4.2	3.7	5.7	5.3	5.9	9.5	8.5
	100	2.6	4.6	3.9	3.4	6.0	5.4	5.2	9.6	7.8
	105	2.5	4.6	3.7	3.2	6.0	4.9	5.0	9.6	7.6
	110	2.4	4.7	3.6	3.0	6.0	4.7	4.7	9.7	7.4
	120	2.1	4.8	3.4	2.7	6.0	4.4	4.1	9.7	6.9
0	90	3.9	5.0	5.3	4.9	6.4	6.7	7.5	10.6	10.5
	100	3.6	5.2	5.0	4.5	6.7	6.4	6.9	11.0	9.9
	105	3.3	5.3	4.8	4.3	6.8	6.2	6.6	11.1	9.7
	110	3.1	5.4	4.6	4.1	6.8	6.0	6.1	11.3	9.2
	120	2.8	5.5	4.4	3.6	6.8	5.5	5.5	11.7	8.7
10	90	5.0	5.4	6.5	6.3	7.0	8.2	9.6	11.7	12.8
	100	4.5	5.7	6.1	5.8	7.4	7.8	8.7	12.3	12.2
	105	4.3	5.9	6.0	5.5	7.5	7.5	8.3	12.6	11.9
	110	4.1	6.0	5.8	5.2	7.6	7.4	7.9	12.8	11.5
	120	3.7	6.2	5.5	4.7	7.8	6.9	7.2	13.4	10.9
20	90	6.2	5.8	7.8	7.9	7.5	10.0	12.2	12.7	15.7
	100	5.7	6.2	7.4	7.3	8.0	9.6	11.1	13.6	14.9
	105	5.4	6.4	7.2	7.0	8.2	9.2	10.6	14.0	14.5
	110	5.2	6.6	7.1	6.7	8.4	9.0	10.0	14.3	14.0
	120	4.6	6.9	6.6	6.0	8.5	8.3	9.0	15.0	13.2

Cap. — Capacity (tons)
kW — Power Input
SDT — Saturated Discharge Temperature (F)
SST — Saturated Suction Temperature (F)
THR — Total Heat Rejection (tons)

NOTE: To ensure proper cooling, it is required that all 6-cylinder compressors operating with R-502 at -10 F SST or below have one of the 2 unloaders disconnected.

Performance data (cont)



COMPRESSOR CAPACITIES (Tons)

R-502

SST	SDT	06EV022			06EW027			06EW033			06EW044		
		Cap.	kW	THR	Cap.	kW	THR	Cap.	kW	THR	Cap.	kW	THR
-10	90	7.2	12.2	10.3	8.2	13.7	11.8	11.0	16.9	15.3	14.4	24.2	20.6
	100	6.4	12.5	9.6	6.5	12.6	9.7	9.8	17.5	14.3	12.9	25.1	19.4
	105	6.0	12.5	9.2	5.5	11.8	8.6	9.2	17.7	13.8	12.1	25.4	18.7
	110	5.6	12.6	8.8	—	—	—	8.7	17.9	13.3	11.4	25.8	18.1
	120	—	—	—	—	—	—	7.6	18.1	12.3	—	—	—
0	90	9.6	13.7	13.2	12.2	16.9	16.5	14.6	19.2	19.5	19.0	27.6	26.2
	100	8.6	14.2	12.3	10.3	16.6	14.6	13.1	20.1	18.3	17.1	28.8	24.6
	105	8.1	14.4	11.8	9.4	16.3	13.6	12.4	20.5	17.7	16.2	29.4	23.9
	110	7.6	14.5	11.4	8.4	15.8	12.5	11.7	20.8	17.1	15.3	30.0	23.1
	120	6.7	14.8	10.5	6.4	14.2	10.1	10.3	21.4	15.9	13.6	30.9	21.6
10	90	12.6	15.1	16.5	16.6	19.3	21.6	19.0	21.4	24.5	24.7	30.8	32.7
	100	11.4	15.8	15.5	14.6	19.9	19.8	17.1	22.6	23.0	22.4	32.5	30.8
	105	10.8	16.1	14.9	13.6	20.0	18.8	16.3	23.1	22.3	21.3	33.3	29.9
	110	10.2	16.4	14.4	12.6	20.0	17.7	15.4	23.7	21.5	20.2	34.1	29.0
	120	9.0	16.9	13.4	10.4	19.4	15.5	13.7	24.6	20.1	18.0	35.5	27.2
20	90	16.3	16.2	20.5	21.6	21.1	27.0	24.3	23.2	30.3	31.5	33.8	40.3
	100	14.7	17.3	19.2	19.4	22.4	25.2	22.1	24.8	28.5	28.7	36.1	38.1
	105	14.0	17.8	18.6	18.3	22.9	24.3	21.0	25.6	27.6	27.4	37.1	37.0
	110	13.3	18.2	18.0	17.2	23.3	23.3	20.0	26.3	26.8	26.0	38.1	35.9
	120	11.9	18.9	16.7	15.0	23.7	21.1	17.9	27.6	25.1	23.4	40.0	33.8

Cap. — Capacity (tons)
kW — Power Input
SDT — Saturated Discharge Temperature (F)
SST — Saturated Suction Temperature (F)
THR — Total Heat Rejection (tons)

NOTE: To ensure proper cooling, it is required that all 6-cylinder compressors operating with R-502 at -10 F SST or below have one of the 2 unloaders disconnected.

COMPRESSOR CAPACITY NOTES

- Compressor capacities are based on 1750 rpm and 15 F subcooling.
- Liquid subcooling, greater than (less than) the 15 F incorporated in the ratings, increases (decreases) system capacity by 1/2 of 1% for each degree of subcooling. When correcting for subcooling, power input does not change. Adjusted total heat rejection (tons) equals adjusted capacity + .285 x kW input.
- Refrigerant temperatures shown are saturation temperatures corresponding to pressure indicated at compressor. Actual gas temperatures are higher because of superheat.
- Capacities are based on actual suction gas temperatures to the compressor of 65 F for R-12, R-500 and R-502. (This assumes superheat is obtained from liquid-suction interchanger or in evaporator.)
Capacity corrections, for other than rated suction gas temperatures, may be obtained from Rating Basis and Capacity Multipliers table. R-22 suction gas superheat for ratings 15 F normally occurs because of expansion valve operation and line losses. Therefore, R-22 ratings can be used without adjustment.



RATING BASIS AND CAPACITY MULTIPLIERS

SST	RATED SUCTION GAS TEMP	ACTUAL SUCTION GAS TEMPERATURE TO COMPRESSOR (F)										
		-30	-20	-10	0	10	20	30	40	50	60	65
-30	65	.810	.830	.850	.870	.890	.910	.930	.950	.970	.990	1.000
-20			.830	.850	.870	.890	.910	.930	.950	.970	.990	1.000
-10				.850	.870	.890	.910	.930	.950	.970	.990	1.000
0					.870	.890	.910	.930	.950	.970	.990	1.000
10					.940	.949	.958	.967	.977	.986	.995	1.000
20						.890	.910	.930	.950	.970	.990	1.000
30						.950	.959	.968	.977	.986	.995	1.000
40							.910	.930	.950	.970	.990	1.000
50							.960	.969	.978	.987	.996	1.000
								.930	.950	.970	.990	1.000
							.970	.979	.987	.996	1.000	
								.950	.970	.990	1.000	
								.987	.992	.997	1.000	
									.970	.990	1.000	
									.997	.999	1.000	

□ R-502

■ R-12, R-500

SST — Saturated Suction Temperature

CAPACITY CONTROL REDUCTION STEPS* AND PART LOAD PERFORMANCE

UNIT	NO. OF CONTR CYL	CAPACITY STEPS (% Full Load Capacity)						
		100	66 $\frac{2}{3}$	50	33 $\frac{1}{3}$			
		% Full Load kW						
		100	76	70	56	48	39	
Number of Active Cylinders								
06D	E824, E537	4	6	4	—	—	2	—
06E	V022	2	4	—	—	2	—	—
	W027, W033, W044	4	6	—	4	—	—	2

*Compressor cylinders unload in response to a self-contained suction-pressure-controlled unloader valve(s) for 06D and 06E compressors. When suction pressure drops below unloader set point, cylinders unload. When suction pressure rises above cylinder load set point pressure, cylinders return to operation. Capacity control unloader set points and differential (load point - unload point) are adjustable.

ARI STANDARD RATING CONDITIONS

GROUP	SST	SDT	RGT	SUBCOOLING
A	45	130	65	15
C	20	120	65	15
E	-10	105	65	5

ARI — Air Conditioning and Refrigeration Institute
 RGT — Return Gas Temperature
 SDT — Saturated Discharge Temperature
 SST — Saturated Suction Temperature

Ratings are in accordance with ARI Standard 520.

ARI STANDARD RATINGS

COMPR 06		GROUP A						GROUP C			GROUP E		
		R-22			R-500			R-12			R-502		
		Cap.	kW	THR	Cap.	kW	THR	Cap.	kW	THR	Cap.	kW	THR
D	A8181	7.6	8.4	10.0	5.7	6.3	7.5	2.9	4.4	4.2	2.3	4.6	3.4
	E8241	9.4	11.0	12.6	7.0	7.9	9.3	3.7	5.3	5.2	3.1	6.0	4.5
	E5371	14.8	17.8	19.9	10.9	12.9	14.6	5.7	7.9	8.0	4.7	9.6	7.0
E	V022	19.8	22.4	25.6	14.6	17.2	19.1	7.3	11.6	10.3	5.7	12.5	8.9
	W027	26.1	29.4	33.7	19.2	22.2	25.0	8.9	13.6	12.4	5.2	11.8	8.3
	W033	29.6	33.1	38.2	21.9	24.7	28.3	11.0	15.8	15.1	8.7	17.7	13.3
	W044	38.6	48.3	51.1	28.5	35.9	37.8	14.5	22.4	20.3	11.5	25.4	18.1

Cap. — Capacity (tons)

kW — Power Input

THR — Total Heat Rejection (tons)

Ratings are in accordance with ARI Standard 520.

UNIT 06		kW	UNIT VOLTAGE														
			208/230					460					575				
			Supply Range*														
			06D and 06E — 187-253					414-508					518-632				
		RLA	LRA	MTA	MCA	MFA	RLA	LRA	MTA	MCA	MFA	RLA	LRA	MTA	MCA	MFA	
D	A8181	10.8	35	137	49	44	70	16	62	22	20	35	13	50	18	17	25
	E8241	14.1	45	170	62	57	100	20	77	28	25	45	16	62	22	20	35
	E5371	20.7	64	266	89	80	125	29	120	40	37	60	23	96	32	29	50
E	V022	24.8	76	345	106	95	150	36	173	50	45	80	29	120	40	37	60
	W027	33.6	100	446	140	125	225	48	223	66	60	100	36	164	50	45	80
	W033	37.6	119	506	166	149	250	53	253	73	67	110	42	176	58	53	90
	W044	55.1	159	690	222	199	350	76	345	106	95	150	60	240	84	75	125

LEGEND

- kW** — Maximum Power Input
- LRA** — Locked Rotor Amps
- MCA** — Minimum Circuit Amps, for wire sizing. Complies with NEC.
- MFA** — Maximum Fuse Amps
- MTA** — Must Trip Amps
- NEC** — National Electrical Code
- RLA** — Rated Load Amps

*Units are suitable for use on electrical systems where voltage supplied to the unit terminals is not below or above the listed range limits.

CONTROL CIRCUIT WIRING SCHEMATIC FOR 06DA8181, E8241, E5371 (Single Pumpout Control)

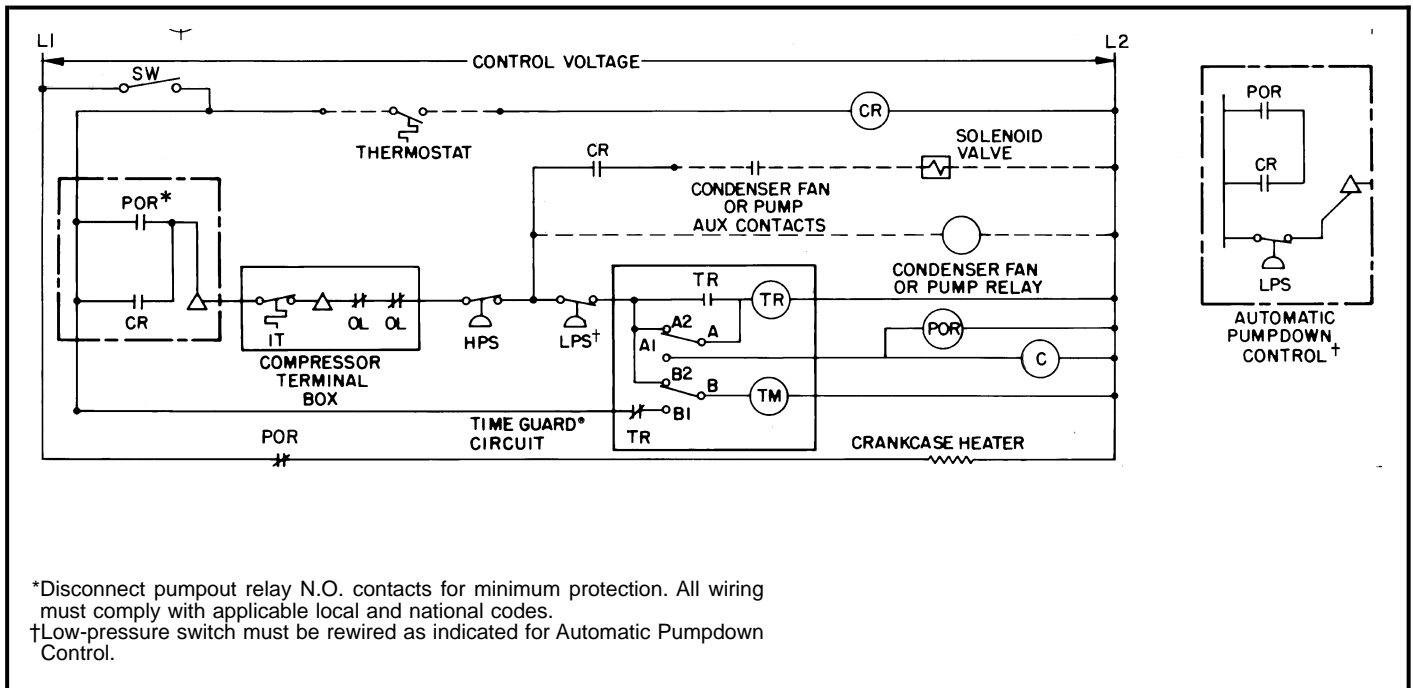

*Disconnect pumpout relay N.O. contacts for minimum protection. All wiring must comply with applicable local and national codes.
 †Low-pressure switch must be rewired as indicated for Automatic Pumpdown Control.

CONTROL CIRCUIT WIRING SCHEMATIC FOR 06EV022, 06EW027, 033, 044

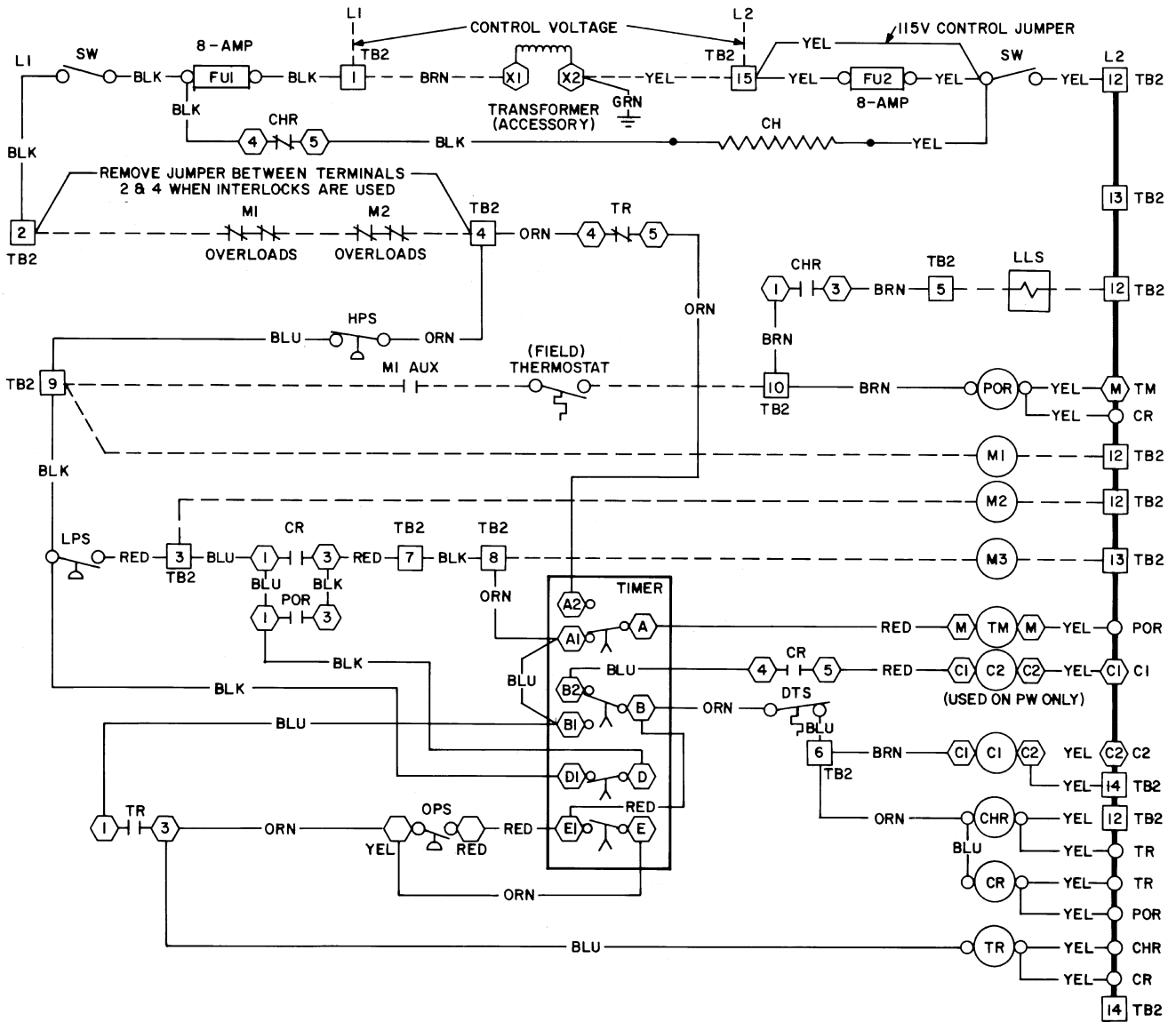

LEGEND

(For 06D and 06E Schematics)

- | | | |
|--|--|---|
| <ul style="list-style-type: none"> Aux — Auxiliary C — Compressor Contactor C1 — Compressor Contactor (XL start and first step of PW start) C2 — Compressor Contactor (PW second step) CH — Crankcase Heater CHR — Crankcase Heater Relay DTS — Discharge Temperature Sensor FU — Fuse HPS — High-Pressure Switch IT — Internal Thermostat | <ul style="list-style-type: none"> LLS — Liquid Line Solenoid Valve LPS — Low-Pressure Switch M1 — Evaporator Fan or Chilled Water Pump M2 — Cooling Tower Pump M3 — Cooling Tower Fan N.O. — Normally Open OI — Overload OPS — Oil-Pressure Switch POR — Pumpout Relay PR — Motor Protector Relay SW — Start-Stop-Reset Switch T — Thermostat | <ul style="list-style-type: none"> TB — Terminal Block TM — Timer Motor TR — Timer Relay — Factory Wiring - - - Field Wiring <p>NOTE: Wiring is shown for single pumpout control. Single pumpout control should not be used on dry-expansion (DX) cooler applications (see lower diagram for wiring when applied with DX cooler).</p> |
|--|--|---|

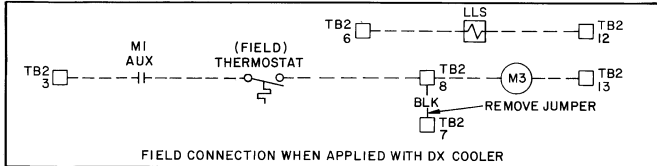

Typical piping and wiring

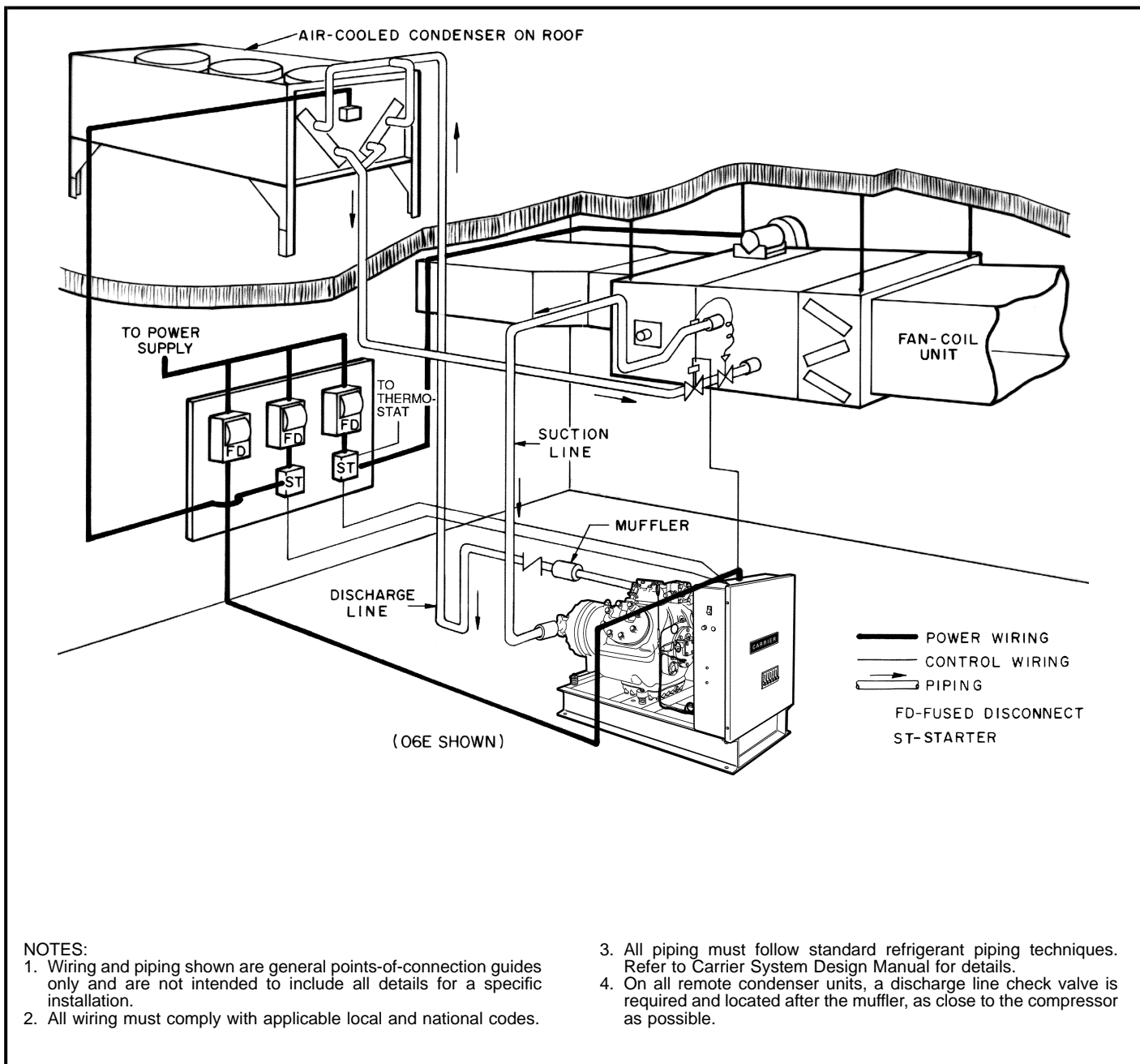

NOTES:

1. Wiring and piping shown are general points-of-connection guides only and are not intended to include all details for a specific installation.
2. All wiring must comply with applicable local and national codes.

3. All piping must follow standard refrigerant piping techniques. Refer to Carrier System Design Manual for details.
4. On all remote condenser units, a discharge line check valve is required and located after the muffler, as close to the compressor as possible.

Application data



Adequate lubrication depends on proper oil return to compressor (especially during unloaded operation) and keeping liquid refrigerant out of crankcase (refrigerant dilutes oil).

Correct system piping design prevents gravity flow of refrigerant to compressor while permitting oil return. Refer to Carrier System Design Manual for correct refrigerant piping techniques.

Crankcase heater energized and **Liquid Line Solenoid** closed during shutdown periods restrict refrigerant migration to compressor and absorption of refrigerant by the oil (minimum protection). A discharge line check valve prevents refrigerant migration from condenser to compressor and should be installed on air cooled applications where condenser or receiver ambient temperature is at or above compressor ambient temperature.

Single pumpout control incorporates a liquid line solenoid valve and prevents refrigerant migration by allowing unit to shut off only after all refrigerant has been removed from evaporator. (Compressor shuts off on low-pressure cutout.)

Automatic pumpdown control allows compressor to cycle on for short intervals during normally "off" periods. This

periodically removes any refrigerant from evaporator which may have accumulated.

This control should not be used with 06D or 06E compressors having cylinder head unloaders.

Dry-expansion cooler applications (excluding brine) should not incorporate single pumpout or automatic pumpdown control. Crankcase heater and liquid line solenoid (minimum protection) are recommended for these applications.

Compressors located in a space subject to low-ambient temperatures require special provision for proper operation during start-up. (Low-ambient temperatures cause compressor to operate at abnormally low suction pressures during start-up.)

Proper operation can be maintained by:

1. Heating the space,
2. A time-delay relay installed to bypass the low-pressure control during start-up, or
3. Use of a suction temperature control to operate compressor, instead of low-pressure control.

06D and 06E Semi-Hermetic Reciprocating Compressor Unit

HVAC Guide Specifications

Size Range: **5 to 15 tons**

Carrier Part Number: **06D**

Size Range: **20 to 40 tons**

Carrier Part Number: **06E**

Part 1 — General

1.01 SYSTEM DESCRIPTION

Reciprocating type, semi-hermetic refrigerant compressor for use with refrigerants R-12, R-22, R-500, or R-502.

1.02 QUALITY ASSURANCE

- A. Unit performance shall be rated according to ARI 520 latest edition and comply with ANSI/ASHRAE 15 safety code, NEC, and ASME Code.
- B. Compressors will be factory run tested to ensure proper performance.

1.03 DELIVERY, STORAGE AND HANDLING

Unit will be stored and handled according to manufacturer's instructions.

Part 2 — Products

2.01 EQUIPMENT

A. General:

Factory assembled single piece, refrigerant compressor unit. Contained within the package shall be a semi-hermetic reciprocating compressor, structural steel base, control panel, power terminal box, wiring, piping, and controls required prior to field start-up.

B. Compressors:

Reciprocating semi-hermetic type only, with shutoff valves, automatically reversible positive displacement oil pump, oil charge, crankcase heater with relay, and suction pressure actuated cylinder unloaders. Unit mounted on vibration isolators.

C. Controls and Safeties:

1. Included in the control panel are power and control terminal blocks, contactors, control relays, on/off switch, and unit designed to start with controlled cylinders unloaded. Factory assembled control box to be tested and mounted on structural base.
2. Safeties in the control box include high- and low-pressure switches, timer to prevent compressor short cycling, overload relays or circuit breakers, and control circuit fuse.

D. Electrical Requirements:

All control and power wiring between control box and compressor shall be factory assembled.

E. Special Features:

Certain standard features are removed and replaced by those features designated by *. Consult your local Carrier sales office for amending specifications.

*** 1. Electric Actuated Unloaders:**

Includes all necessary hardware to allow field conversion from suction pressure actuated to electric solenoid actuated unloaders.

*** 2. Water-Cooled Condenser:**

Multipass shell and tube with integral finned copper tubes for field installation. Shall be factory tested to comply with ASME Code for unfired pressure vessels, ARI Standard 450 for condensers, and ANSI/ASHRAE safety code. Equipped with pressure relief, liquid line shutoff, and connection for water regulating valve.

*** 3. Discharge Muffler:**

Unit shall be equipped with a discharge line muffler for noise reduction.



Manufacturer reserves the right to discontinue, or change at any time, specifications or designs without notice and without incurring obligations.