



# Product Data

# 06DA,DE,DH 06EV,EW Compressor Units

3 to 40 Nominal Tons



## 06D,06E Compressors

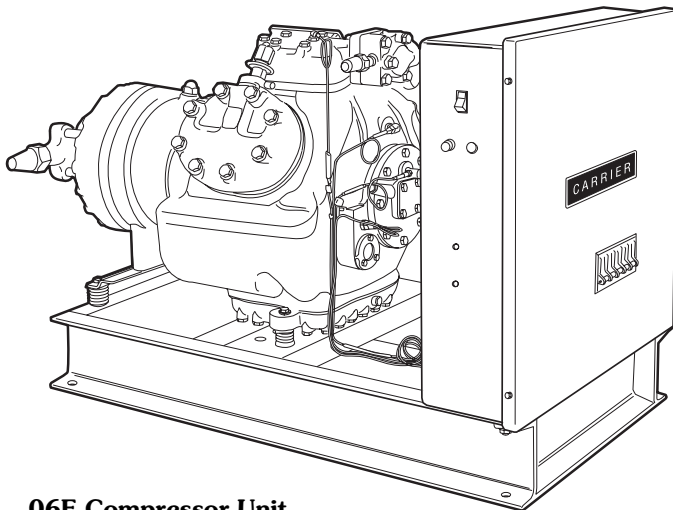

06E Compressor Unit

### A quality compressor for the right application

The Carlyle line of 06D, 06E semi-hermetic compressors is designed for light, medium, or heavy duty applications from 3 through 40 tons. Use them with complete confidence for air conditioning or refrigeration, with either water-cooled, air-cooled, or evaporative condensers.

## Features/Benefits

### System dependability

Reliable trouble-free operation and long unit life is assured with this motor-compressor. The hermetically sealed unit eliminates dirt, air, and moisture contamination in the refrigeration system, and also eliminates shaft seal and alignment problems. Compressor wear is minimized by the positive pressure lubrication provided with a built-in oil pressure regulator and an automatically reversible oil pump.

### Operating efficiency

Power conserving capacity control valves on Carlyle compressors provide the most efficient operation at the lowest cost. These valves automatically match the compressor capacity to system load variations.

Suction cutoff unloading further reduces energy usage during unloaded operation. Valve body shuts off passage from suction manifold, preventing charge from unnecessarily being pulled into cylinder. This results in an EER (Energy Efficiency Ratio) improvement of as much as 39.5% at 33% load.

Rely with confidence on the overall protection devices built into these fine compressors. The Time Guard® circuit prevents rapid compressor cycling. High- and low-pressure switches protect against excessive motor loads due to refrigeration system problems.

A lightweight crankcase, made of fine grain cast iron, meets all code pressure requirements. Large refrigerant gas passages guarantee low pressure losses and higher compression efficiency as well as providing for motor cooling.

Sound level is kept at a minimum with a discharge line muffler. This muffler is an accessory for the 06D and 06E compressors.

# Table of contents



	Page
Features/Benefits . . . . .	1
Model Number Nomenclature . . . . .	2,3
Physical Data . . . . .	3
Base Unit Dimensions. . . . .	4,5
Selection Procedure . . . . .	6
Performance Data . . . . .	6-15
Electrical Data . . . . .	16,17
Typical Wiring Schematics . . . . .	18-20
Typical Piping and Wiring . . . . .	21
Application Data . . . . .	22
Guide Specifications . . . . .	23

## Model number nomenclature

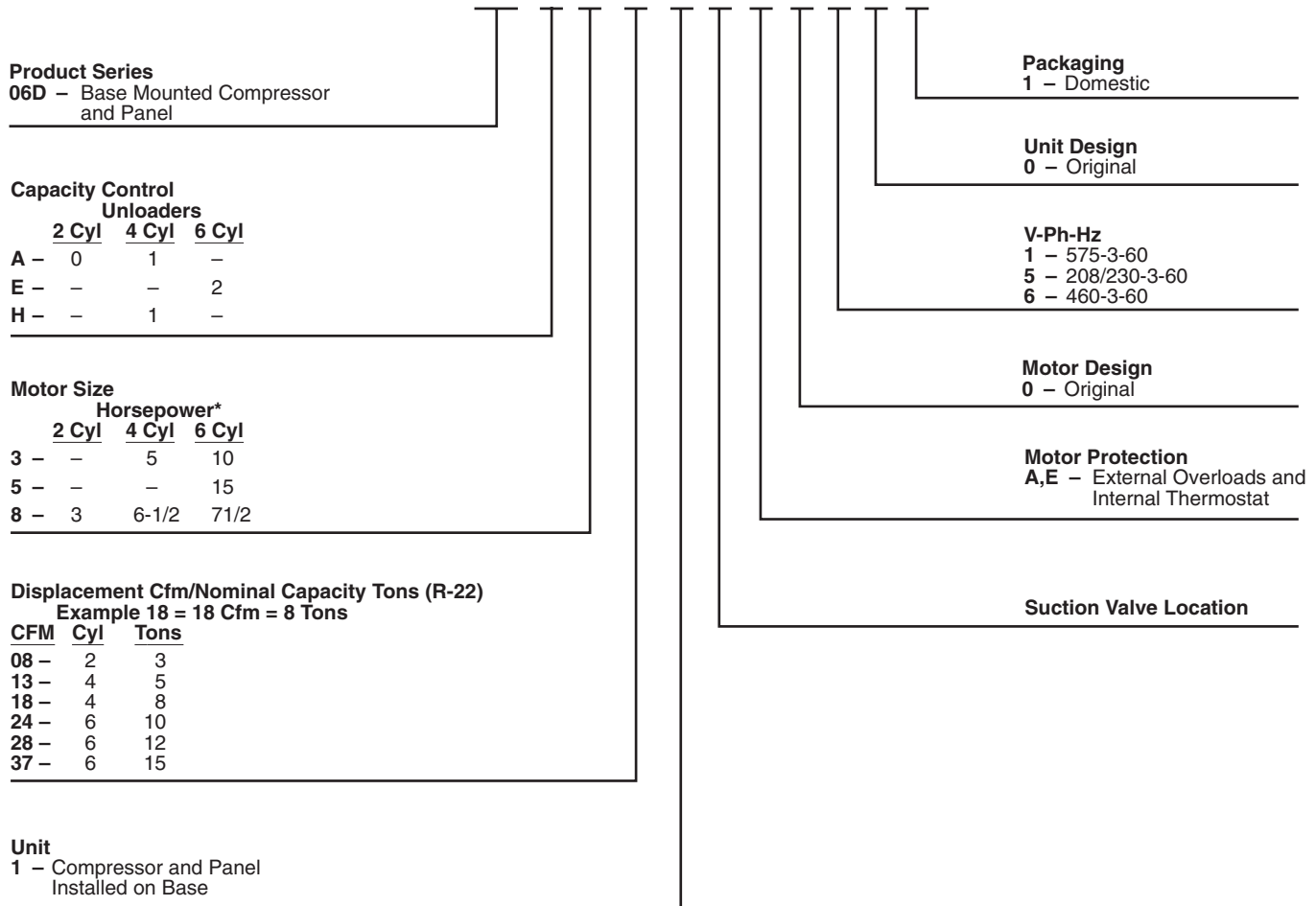

\*Standard hp ratings for R-22 units. Consult Carrier Sales Representative for other refrigerant ratings.

# Model number nomenclature (cont)

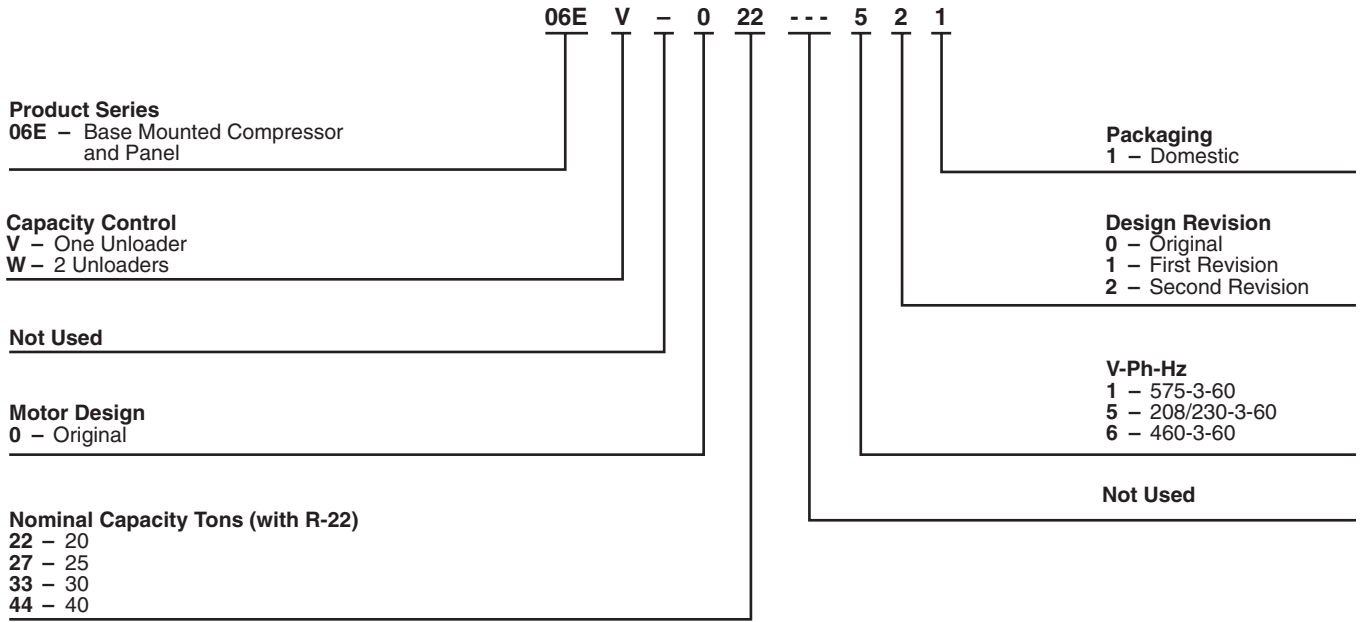

## Physical data

UNIT 06D	A8081	H3131	A8181	E8241	E3281	E5371
<b>OPERATING WEIGHT (lb)</b>	180	250	265	325	325	330
<b>REFRIGERANT</b>	R-134A, R-22, R-507/404A					
<b>COMPRESSOR — 06D*</b>	M808	M313	A818	A824	A328	A537
Cylinders	2	4	4	6	6	6
Bore (in.)	2	2	2	2	2	2
Stroke (in.)	1 <sup>1</sup> / <sub>4</sub>	1	17 <sup>1</sup> / <sub>16</sub>	1 <sup>1</sup> / <sub>4</sub>	115 <sup>1</sup> / <sub>32</sub>	115 <sup>1</sup> / <sub>16</sub>
Displacement (cfm at 1750 rpm)	8	13	18.3	23.9	28	37.1
Maximum Rpm	1750					
Oil Charge (pt)	3	4.5	5.5	8	8	8
High Side Maximum Pressure	450 PSIG					
Low Side Maximum Pressure	245 PSIG					
<b>CONNECTIONS (in.)</b>						
Suction Valve (ODF)	7 <sup>7</sup> / <sub>8</sub>	7 <sup>7</sup> / <sub>8</sub>	1 <sup>1</sup> / <sub>8</sub>	1 <sup>3</sup> / <sub>8</sub>	1 <sup>3</sup> / <sub>8</sub>	1 <sup>3</sup> / <sub>8</sub>
Discharge Valve (ODF)	5 <sup>5</sup> / <sub>8</sub>	5 <sup>5</sup> / <sub>8</sub>	7 <sup>7</sup> / <sub>8</sub>	7 <sup>7</sup> / <sub>8</sub>	7 <sup>7</sup> / <sub>8</sub>	1 <sup>1</sup> / <sub>8</sub>

\*Compressors listed are for R-22 applications. For R-134A and R-507/404A an 06DR compressor is standard. Factory compressor substitutes may be made. Contact Carrier Sales Representative.

UNIT 06E	V022	W027	W033	W044
<b>OPERATING WEIGHT (lb)</b>	600	640	650	670
<b>REFRIGERANT</b>	R-134A, R-22, R-507/404A			
<b>COMPRESSOR — 06E*</b>	A250	A265	A275	A299
Cylinders	4	6	6	6
Bore (in.)	2 <sup>11</sup> / <sub>16</sub>	2 <sup>11</sup> / <sub>16</sub>	2 <sup>11</sup> / <sub>16</sub>	2 <sup>11</sup> / <sub>16</sub>
Stroke (in.)	2 <sup>3</sup> / <sub>16</sub>	2	2 <sup>3</sup> / <sub>16</sub>	2 <sup>7</sup> / <sub>8</sub>
Displacement (cfm at 1750 rpm)	50	68	75	99
Maximum Rpm	1750			
Oil Charge (pt)	14	19	19	19
High Side Maximum Pressure	450 PSIG			
Low Side Maximum Pressure	245 PSIG			
<b>CONNECTIONS (in.)</b>				
Suction Valve (ODF)	1 <sup>5</sup> / <sub>8</sub>	1 <sup>5</sup> / <sub>8</sub>	2 <sup>1</sup> / <sub>8</sub>	2 <sup>1</sup> / <sub>8</sub>
Discharge Valve (ODF)	1 <sup>1</sup> / <sub>8</sub>	1 <sup>3</sup> / <sub>8</sub>	1 <sup>3</sup> / <sub>8</sub>	1 <sup>5</sup> / <sub>8</sub>

### LEGEND

**ODF** — Outside Diameter Female

\*Compressors listed are for R-22 applications. For R-134A an 06EM compressor is standard offering; an 06ER compressor is standard for R-507/404A. Factory compressor substitutes may be made. Contact Carrier Sales Representative.

# Base unit dimensions



## 06D COMPRESSOR UNIT

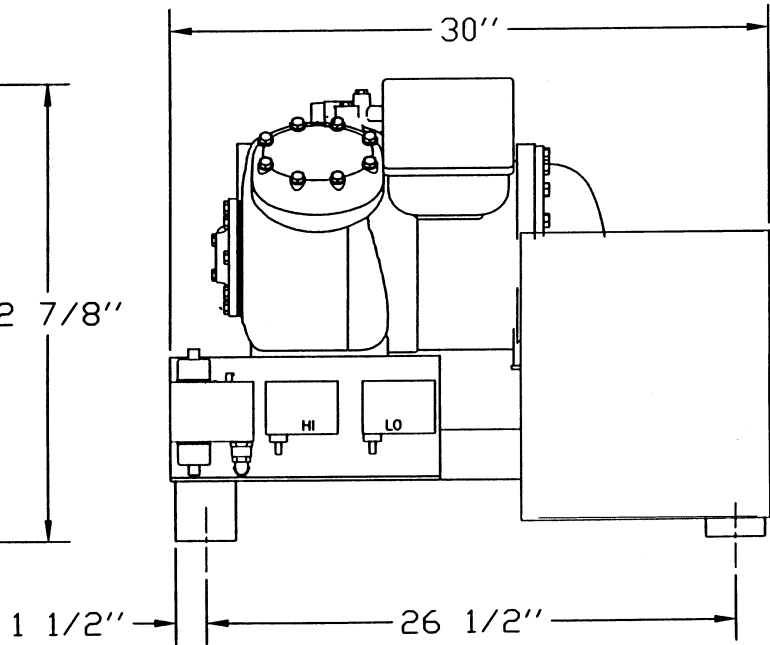
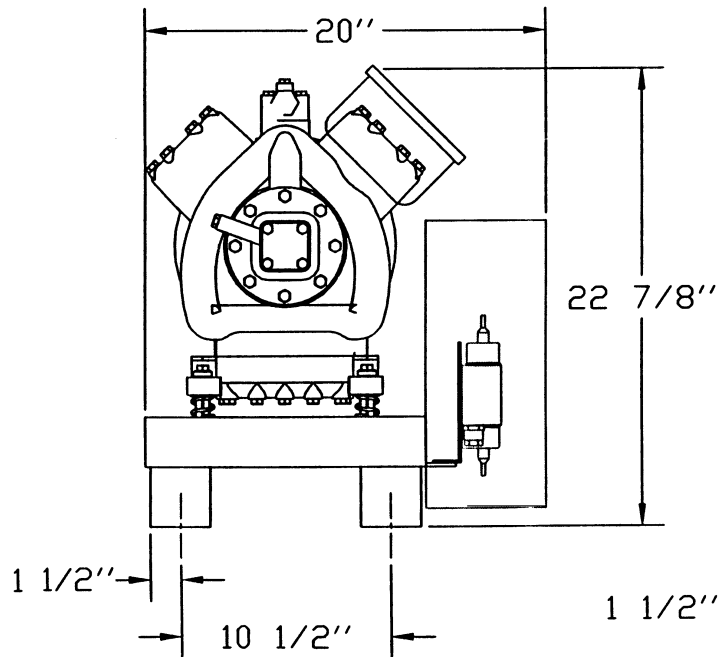
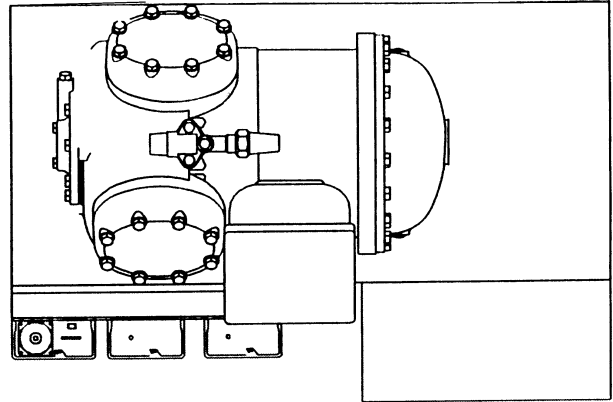

### 06E COMPRESSOR UNIT

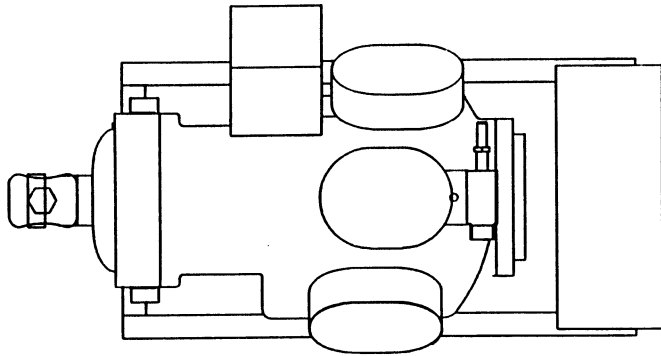

NOTE: Recommended service space is 3 ft-0 in. at compressor motor end to allow for motor removal.

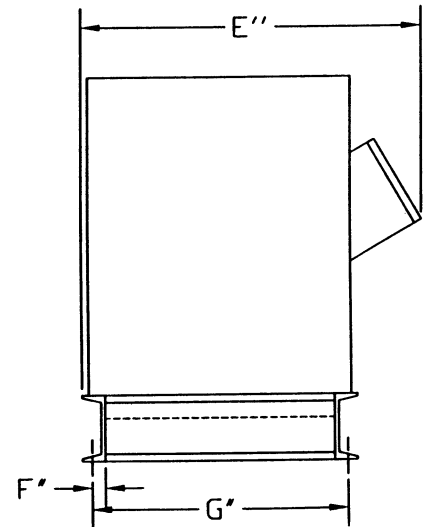
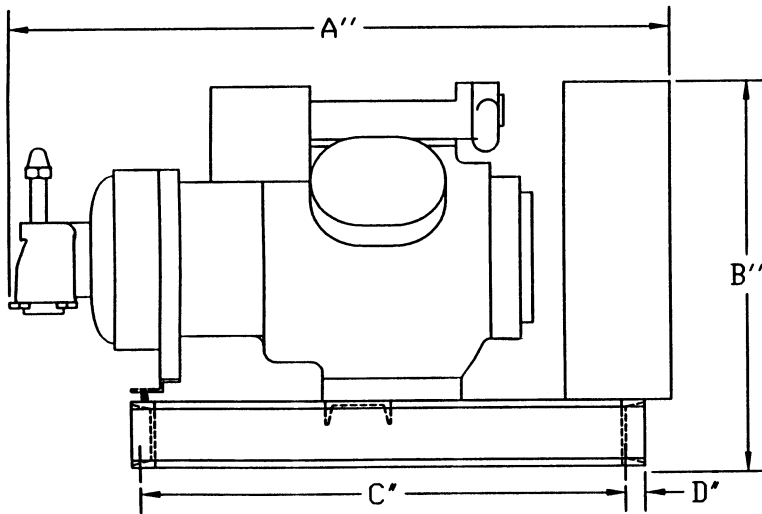

#### DIMENSIONS (in.)

06E UNIT	VOLTAGE	A	B	C	D	E	F	G
V022	208/230	48 <sup>1</sup> / <sub>4</sub>	35	36 <sup>7</sup> / <sub>8</sub>	1 <sup>1</sup> / <sub>2</sub>	27 <sup>1</sup> / <sub>2</sub>	1	19 <sup>1</sup> / <sub>2</sub>
	460,575	48 <sup>1</sup> / <sub>4</sub>	29	36 <sup>7</sup> / <sub>8</sub>	1 <sup>1</sup> / <sub>2</sub>	26	1	19 <sup>1</sup> / <sub>2</sub>
W027	208/230	50 <sup>1</sup> / <sub>4</sub>	35	36 <sup>7</sup> / <sub>8</sub>	1 <sup>1</sup> / <sub>2</sub>	27 <sup>1</sup> / <sub>2</sub>	1	19 <sup>1</sup> / <sub>2</sub>
	460,575	50 <sup>1</sup> / <sub>4</sub>	29	36 <sup>7</sup> / <sub>8</sub>	1 <sup>1</sup> / <sub>2</sub>	26	1	19 <sup>1</sup> / <sub>2</sub>
W033	208/230	50 <sup>1</sup> / <sub>4</sub>	35	36 <sup>7</sup> / <sub>8</sub>	1 <sup>1</sup> / <sub>2</sub>	27 <sup>1</sup> / <sub>2</sub>	1	19 <sup>1</sup> / <sub>2</sub>
	460,575	50 <sup>1</sup> / <sub>4</sub>	29	36 <sup>7</sup> / <sub>8</sub>	1 <sup>1</sup> / <sub>2</sub>	26	1	19 <sup>1</sup> / <sub>2</sub>
W044	208/230	50 <sup>1</sup> / <sub>4</sub>	35	36 <sup>7</sup> / <sub>8</sub>	1 <sup>1</sup> / <sub>2</sub>	27 <sup>1</sup> / <sub>2</sub>	1	19 <sup>1</sup> / <sub>2</sub>
	460,575	50 <sup>1</sup> / <sub>4</sub>	35	36 <sup>7</sup> / <sub>8</sub>	1 <sup>1</sup> / <sub>2</sub>	27 <sup>1</sup> / <sub>2</sub>	1	19 <sup>1</sup> / <sub>2</sub>

# Selection procedure



## I Determine refrigerant, load, saturated suction temperature, and saturated discharge temperature.

Given:

Refrigerant . . . . . R-22  
 Cooling Load . . . . . 40 Tons  
 Saturated Suction Temperature . . . . . 40 F  
 Saturated Discharge Temperature . . . . . 105 F

**selection, power input (kW) requirements, and total heat rejection (THR). (Use direct interpolation where job requirements fall between values shown. Do not extrapolate.)**

Select an 06EW044 which has a cooling capacity of 42.7 tons at a saturated suction temperature of 40 F and saturated discharge temperature of 105 F. Motor-compressor power input is 37.3 kW and total heat rejection is 53.3 tons.

Refer to Compressor Capacities notes for information concerning basis for compressor ratings and capacity corrections due to refrigerant superheat or subcooling.

## II Enter Compressor Capacities table for correct refrigerant at required suction and discharge temperatures. Read across until a suitable capacity is found. Determine motor-compressor

# Performance data

**COMPRESSOR CAPACITIES (Tons)\***  
**R-134A**

SST	SDT	06DH3131			06DA8181			06DE8241		
		Cap.	kW	THR	Cap.	kW	THR	Cap.	kW	THR
0	90	1.37	1.78	1.88	2.25	2.70	3.02	2.81	3.29	3.75
	100	1.21	1.83	1.73	2.06	2.83	2.86	2.51	3.40	3.48
	110	1.05	1.84	1.58	1.87	2.93	2.71	2.21	3.48	3.20
	120	0.90	1.83	1.42	1.69	3.01	2.55	1.92	3.50	2.91
	130	0.76	1.78	1.27	1.52	3.08	2.40	1.64	3.48	2.63
	140	0.62	1.70	1.10	1.36	3.12	2.25	1.37	3.39	2.33
	145	0.55	1.64	1.02	1.28	3.13	2.17	1.25	3.30	2.19
10	90	1.90	2.02	2.47	3.00	3.03	3.87	3.86	3.78	4.94
	100	1.70	2.12	2.30	2.76	3.22	3.67	3.48	3.98	4.62
	110	1.51	2.19	2.13	2.52	3.38	3.48	3.11	4.13	4.29
	120	1.32	2.23	1.96	2.29	3.52	3.29	2.75	4.25	3.96
	130	1.14	2.24	1.78	2.07	3.63	3.10	2.40	4.32	3.64
	140	0.97	2.21	1.60	1.85	3.72	2.91	2.07	4.33	3.30
	145	0.89	2.18	1.51	1.75	3.76	2.82	1.90	4.31	3.13
20	90	2.55	2.22	3.18	3.94	3.30	4.88	5.15	4.25	6.36
	100	2.31	2.38	2.99	3.63	3.57	4.64	4.69	4.53	5.98
	110	2.07	2.51	2.79	3.32	3.81	4.41	4.24	4.77	5.60
	120	1.84	2.62	2.59	3.03	4.02	4.18	3.79	4.98	5.21
	130	1.62	2.68	2.39	2.75	4.20	3.94	3.36	5.14	4.83
	140	1.41	2.71	2.18	2.47	4.35	3.71	2.94	5.26	4.44
	145	1.30	2.71	2.08	2.34	4.41	3.60	2.74	5.30	4.25
30	90	3.34	2.36	4.02	5.09	3.48	6.08	6.72	4.69	8.05
	100	3.05	2.59	3.79	4.70	3.85	5.79	6.16	5.05	7.60
	110	2.77	2.79	3.56	4.32	4.19	5.51	5.61	5.38	7.14
	120	2.49	2.96	3.33	3.95	4.48	5.22	5.07	5.68	6.68
	130	2.21	3.10	3.10	3.59	4.74	4.94	4.53	5.95	6.23
	140	1.95	3.19	2.86	3.24	4.97	4.66	4.02	6.17	5.78
	145	1.82	3.23	2.74	3.07	5.07	4.52	3.76	6.26	5.55
40	90	4.31	2.42	5.00	6.50	3.54	7.50	8.61	5.08	10.06
	100	3.95	2.72	4.73	6.01	4.03	7.15	7.94	5.53	9.51
	110	3.61	3.00	4.46	5.53	4.48	6.81	7.27	5.95	8.96
	120	3.26	3.25	4.19	5.07	4.88	6.46	6.61	6.35	8.42
	130	2.93	3.46	3.92	4.62	5.24	6.11	5.96	6.72	7.87
	140	2.60	3.64	3.64	4.18	5.56	5.76	5.32	7.04	7.33
	145	2.44	3.71	3.50	3.96	5.71	5.59	5.01	7.19	7.06
50	90	5.46	2.44	6.16	8.20	3.60	9.22	10.89	5.42	12.43
	100	5.04	2.77	5.83	7.59	4.06	8.75	10.07	5.96	11.77
	110	4.62	3.13	5.51	7.00	4.64	8.32	9.26	6.48	11.11
	120	4.20	3.46	5.19	6.42	5.17	7.90	8.46	6.98	10.45
	130	3.79	3.76	4.87	5.86	5.65	7.47	7.67	7.45	9.79
	140	3.40	4.02	4.54	5.31	6.09	7.05	6.89	7.89	9.14
	145	3.20	4.14	4.38	5.16	6.30	6.95	6.51	8.09	8.81

**LEGEND**

- Cap. — Capacity (tons)
- kW — Power Input
- SDT — Saturated Discharge Temperature (F)
- SST — Saturated Suction Temperature (F)
- THR — Total Heat Rejection (tons)

\*Refer to compressor capacity notes, page 14.

# Performance data (cont)



## COMPRESSOR CAPACITIES (Tons)\* (cont) R-134A (cont)

SST	SDT	06DE3281			06DE5371		
		Cap.	kW	THR	Cap.	kW	THR
0	90	3.47	4.22	4.67	4.79	5.76	6.43
	100	3.18	4.42	4.44	4.43	6.08	6.16
	110	2.89	4.58	4.20	4.05	6.35	5.86
	120	2.60	4.69	3.94	3.67	6.57	5.55
	130	2.31	4.75	3.66	3.28	6.72	5.20
	140	2.02	4.75	3.37	2.88	6.78	4.81
	145	1.88	4.73	3.23	2.68	6.77	4.61
10	90	4.58	4.69	5.92	6.23	6.33	8.04
	100	4.24	4.99	5.66	5.82	6.76	7.75
	110	3.89	5.25	5.39	5.38	7.17	7.43
	120	3.54	5.47	5.10	4.95	7.52	7.09
	130	3.19	5.64	4.80	4.49	7.83	6.72
	140	2.84	5.75	4.48	4.02	8.06	6.32
	145	2.67	5.79	4.32	3.78	8.15	6.11
20	90	5.93	5.10	7.38	7.98	6.85	9.93
	100	5.52	5.51	7.09	7.48	7.40	9.59
	110	5.10	5.88	6.77	6.98	7.92	9.23
	120	4.68	6.21	6.45	6.44	8.41	8.84
	130	4.25	6.49	6.10	5.91	8.86	8.43
	140	3.83	6.73	5.75	5.36	9.26	8.00
	145	3.62	6.82	5.56	5.08	9.43	7.77
30	90	7.54	5.41	9.08	10.04	7.31	12.12
	100	7.04	5.94	8.74	9.45	7.96	11.72
	110	6.54	6.43	8.37	8.84	8.61	11.29
	120	6.03	6.88	7.99	8.22	9.23	10.85
	130	5.52	7.29	7.60	7.59	9.82	10.39
	140	5.01	7.66	7.19	6.93	10.40	9.90
	145	4.75	7.82	6.98	6.61	10.60	9.63
40	90	9.46	5.62	11.06	12.49	7.69	14.68
	100	8.86	6.27	10.65	11.78	8.46	14.19
	110	8.26	6.89	10.22	11.05	9.22	13.68
	120	7.65	7.47	9.78	10.31	9.97	13.15
	130	7.03	8.02	9.32	9.55	10.70	12.60
	140	6.41	8.52	8.84	8.77	11.40	12.02
	145	6.10	8.75	8.59	8.38	11.70	11.72
50	90	11.73	5.67	13.35	15.38	7.99	17.66
	100	11.02	6.46	12.86	14.53	8.87	17.06
	110	10.29	7.23	12.35	13.66	9.76	16.44
	120	9.56	7.95	11.82	12.76	10.64	15.80
	130	8.81	8.64	11.28	11.85	11.51	15.13
	140	8.07	9.29	10.71	10.92	12.36	14.44
	145	7.69	9.59	10.42	10.44	12.78	14.08

### LEGEND

- Cap.** — Capacity (tons)
- kW** — Power Input
- SDT** — Saturated Discharge Temperature (F)
- SST** — Saturated Suction Temperature (F)
- THR** — Total Heat Rejection (tons)

\*Refer to compressor capacity notes, page 14.

# Performance data (cont)



## COMPRESSOR CAPACITIES (Tons)\* (cont) R-134A (cont)

SST	SDT	06EV022			06EW027			06EW033			06EW044		
		Cap.	kW	THR	Cap.	kW	THR	Cap.	kW	THR	Cap.	kW	THR
0	90	5.11	6.83	7.06	6.64	8.52	9.07	8.13	10.30	11.07	10.92	14.70	15.11
	100	4.55	6.88	6.51	5.73	8.39	8.12	7.25	10.40	10.21	9.84	14.90	14.08
	110	3.99	6.85	5.95	4.82	8.08	7.12	6.35	10.40	9.31	8.78	15.00	13.06
	120	3.46	6.73	5.38	3.92	7.56	6.08	5.45	10.10	8.33	7.77	14.90	12.01
	130	2.95	6.53	4.81	3.05	6.83	4.99	4.55	9.68	7.31	6.79	14.70	10.98
	140	2.22	6.07	3.95	1.75	5.20	3.22	3.22	8.55	5.66	5.40	14.10	9.42
	145	1.77	5.80	3.41	0.96	4.20	2.17	2.36	7.48	4.50	4.53	13.60	8.41
10	90	7.03	7.84	9.26	9.40	10.10	12.28	11.09	11.90	14.48	14.81	17.00	19.66
	100	6.33	8.04	8.62	8.32	10.30	11.26	10.05	12.30	13.56	13.46	17.40	18.42
	110	5.65	8.15	7.97	7.25	10.20	10.15	9.01	12.50	12.57	12.14	17.70	17.19
	120	4.99	8.17	7.32	6.18	10.00	9.03	7.95	12.60	11.54	10.87	17.90	15.97
	130	4.35	8.09	6.65	5.14	9.53	7.86	6.84	12.40	10.37	9.63	17.90	14.73
	140	3.44	7.80	5.66	3.64	8.40	6.03	5.33	11.80	8.69	7.86	17.60	12.88
	145	2.86	7.49	5.00	2.69	7.33	4.78	4.31	11.00	7.45	6.74	17.20	11.65
20	90	9.39	8.78	11.89	12.77	11.55	16.07	14.64	13.20	18.40	19.62	19.10	25.06
	100	8.54	9.17	11.15	11.50	12.04	14.93	13.43	13.97	17.41	17.95	19.90	23.62
	110	7.71	9.45	10.40	10.22	12.33	13.73	12.20	14.56	16.35	16.31	20.60	22.19
	120	6.89	9.63	9.63	8.96	12.40	12.49	10.96	14.96	15.23	14.72	21.00	20.71
	130	6.10	9.71	8.86	7.71	12.24	11.20	9.72	15.15	14.04	13.17	21.30	19.24
	140	4.96	9.63	7.70	5.90	11.55	9.20	7.87	15.02	12.15	10.94	21.40	17.04
	145	4.23	9.44	6.92	4.75	10.78	7.82	6.65	14.62	10.82	9.52	21.20	15.56
30	90	12.28	9.57	15.01	16.84	12.69	20.46	18.90	14.25	22.96	25.49	21.10	31.51
	100	11.24	10.20	14.15	15.33	13.57	19.20	17.47	15.40	21.86	23.44	22.30	29.80
	110	10.22	10.70	13.27	13.82	14.24	17.88	16.02	16.37	20.69	21.42	23.30	28.06
	120	9.22	11.10	12.38	12.32	14.68	16.50	14.56	17.15	19.45	19.45	24.20	26.35
	130	8.24	11.30	11.46	10.83	14.88	15.07	13.09	17.72	18.14	17.53	24.80	24.60
	140	6.83	11.50	10.11	8.66	14.71	12.85	10.89	18.16	16.06	14.74	25.30	21.95
	145	5.92	5.70	7.55	7.26	14.28	11.33	9.43	18.16	14.60	12.95	25.50	20.22
40	90	15.77	10.10	18.65	21.72	13.40	25.54	23.96	14.90	28.20	32.61	22.70	39.08
	100	14.51	11.00	17.65	19.93	14.80	24.15	22.27	16.50	26.97	30.10	24.50	37.08
	110	13.27	11.80	16.63	18.14	15.90	22.67	20.56	17.90	25.66	27.63	26.00	35.04
	120	12.05	12.40	15.58	16.35	16.70	21.11	18.82	19.10	24.27	25.20	27.20	32.95
	130	10.85	12.90	14.53	14.58	17.30	19.51	17.08	20.10	22.81	22.82	28.30	30.89
	140	9.11	13.40	12.92	11.96	17.80	17.04	14.46	21.20	20.50	19.36	29.40	27.74
	145	7.98	13.60	11.86	10.27	17.70	15.31	12.71	21.60	18.87	17.12	29.90	25.64
50	90	19.96	10.40	22.92	27.54	13.64	31.43	29.95	15.07	34.25	41.17	23.90	47.98
	100	18.44	11.61	21.75	25.42	15.49	29.83	27.95	17.13	32.83	38.11	26.20	45.58
	110	16.93	12.67	20.54	23.28	17.09	28.15	25.92	19.00	31.33	35.09	28.30	43.16
	120	15.45	13.58	19.32	21.15	18.44	26.41	23.86	20.67	29.75	32.12	30.10	40.70
	130	13.99	14.36	18.08	19.04	19.54	24.61	21.79	22.14	28.10	29.21	31.60	38.21
	140	11.85	15.25	16.19	15.90	20.67	21.79	18.66	23.91	25.47	24.93	33.50	34.48
	145	10.46	15.67	14.92	13.85	21.07	19.86	16.56	24.80	23.63	22.15	34.40	31.95

### LEGEND

- Cap. — Capacity (tons)
- kW — Power Input
- SDT — Saturated Discharge Temperature (F)
- SST — Saturated Suction Temperature (F)
- THR — Total Heat Rejection (tons)

\*Refer to compressor capacity notes, page 14.



**COMPRESSOR CAPACITIES (Tons)\* (cont)**  
**R-22**

SST	SDT	06DA8081			06DH3131			06DA8181		
		Cap.	kW	THR	Cap.	kW	THR	Cap.	kW	THR
0	90	1.48	1.90	2.02	2.26	3.02	3.12	3.35	4.16	4.54
	100	1.34	1.98	1.90	2.02	3.11	2.90	3.02	4.32	4.25
	110	1.20	2.04	1.78	1.78	3.16	2.68	2.69	4.42	3.95
	120	1.05	2.10	1.64	1.54	3.20	2.44	2.36	4.45	3.63
	130	0.92	2.10	1.50	1.32	3.10	2.21	2.04	4.40	3.29
	140	0.78	2.00	1.36	1.11	3.00	1.96	1.73	4.30	2.95
	145	0.72	2.00	1.29	1.00	2.90	1.84	1.58	4.20	2.78
10	90	1.96	2.05	2.54	3.02	3.29	3.96	4.44	4.57	5.74
	100	1.79	2.19	2.41	2.74	3.46	3.73	4.05	4.85	5.44
	110	1.62	2.30	2.28	2.46	3.59	3.48	3.67	5.07	5.11
	120	1.46	2.39	2.14	2.18	3.68	3.23	3.28	5.22	4.77
	130	1.29	2.44	1.99	1.91	3.71	2.97	2.90	5.30	4.41
	140	1.14	2.50	1.84	1.66	3.70	2.71	2.55	5.30	4.06
	145	1.06	2.50	1.76	1.54	3.70	2.58	2.37	5.30	3.87
20	90	2.52	2.16	3.13	3.94	3.47	4.93	5.73	4.86	7.12
	100	2.33	2.35	3.00	3.61	3.73	4.67	5.28	5.26	6.78
	110	2.13	2.52	2.85	3.28	3.95	4.41	4.84	5.61	6.43
	120	1.94	2.66	2.70	2.95	4.13	4.13	4.39	5.90	6.07
	130	1.75	2.77	2.54	2.63	4.25	3.84	3.94	6.12	5.68
	140	1.57	2.90	2.38	2.33	4.30	3.57	3.52	6.30	5.30
	145	1.48	2.90	2.30	2.18	4.30	3.42	3.31	6.30	5.11
30	90	3.18	2.20	3.81	5.04	3.56	6.05	7.26	5.01	8.68
	100	2.96	2.45	3.66	4.65	3.91	5.76	6.74	5.55	8.32
	110	2.73	2.67	3.50	4.26	4.23	5.46	6.22	6.03	7.93
	120	2.51	2.87	3.33	3.87	4.50	5.16	5.69	6.46	7.53
	130	2.28	3.05	3.15	3.49	4.72	4.84	5.17	6.82	7.11
	140	2.08	3.20	2.99	3.15	4.90	4.54	4.69	7.10	6.71
	145	1.97	3.30	2.90	2.97	5.00	4.38	4.44	7.20	6.50
40	90	3.96	2.18	4.58	6.32	3.52	7.32	9.04	4.99	10.46
	100	3.70	2.48	4.41	5.87	3.98	7.00	8.44	5.67	10.05
	110	3.44	2.77	4.23	5.41	4.39	6.66	7.83	6.30	9.63
	120	3.18	3.03	4.04	4.96	4.77	6.32	7.23	6.88	9.19
	130	2.91	3.27	3.85	4.52	5.10	5.97	6.62	7.40	8.72
	140	2.68	3.50	3.67	4.12	5.40	5.65	6.07	7.80	8.30
	145	2.55	3.60	3.57	3.91	5.50	5.47	5.78	8.00	8.07
50	90	4.79	2.10	5.38	7.70	3.30	8.65	10.95	4.80	12.31
	100	4.51	2.40	5.21	7.21	3.90	8.32	10.31	5.60	11.90
	110	4.23	2.80	5.03	6.72	4.40	7.98	9.66	6.40	11.48
	120	3.95	3.10	4.84	6.23	4.90	7.63	9.00	7.10	11.03
	130	3.67	3.40	4.64	5.75	5.40	7.27	8.35	7.80	10.57
	140	3.38	3.70	4.44	5.26	5.80	6.90	7.69	8.40	10.08
	145	3.24	3.80	4.33	5.02	5.90	6.71	7.36	8.70	9.83

**LEGEND**

- Cap.** — Capacity (tons)
- kW** — Power Input
- SDT** — Saturated Discharge Temperature (F)
- SST** — Saturated Suction Temperature (F)
- THR** — Total Heat Rejection (tons)

\*Refer to compressor capacity notes, page 14.

NOTE: To ensure proper motor cooling, it is required that all 6-cylinder compressors operating with R-22 at 20 F SST or below have one of the 2 unloaders disconnected.

# Performance data (cont)



## COMPRESSOR CAPACITIES (Tons)\* (cont) R-22 (cont)

SST	SDT	06DE8241			06DE3281			06DE5371		
		Cap.	kW	THR	Cap.	kW	THR	Cap.	kW	THR
0	90	4.23	5.27	5.73	5.25	6.55	7.11	7.29	9.17	9.90
	100	3.81	5.54	5.39	4.81	6.90	6.77	6.72	9.67	9.48
	110	3.40	5.75	5.04	4.38	7.21	6.44	6.17	10.11	9.06
	120	3.01	5.90	4.70	3.97	7.47	6.10	5.64	10.48	8.63
	130	2.64	5.99	4.35	3.58	7.68	5.77	5.13	10.79	8.20
	140	2.30	6.00	4.01	3.22	7.90	5.45	4.66	11.00	7.80
	145	2.13	6.00	3.84	3.04	7.90	5.29	4.43	11.20	7.62
10	90	5.63	5.76	7.27	6.86	7.10	8.88	9.44	10.03	12.30
	100	5.12	6.15	6.87	6.31	7.58	8.47	8.74	10.74	11.80
	110	4.62	6.49	6.47	5.79	8.02	8.07	8.06	11.37	11.30
	120	4.15	6.77	6.08	5.28	8.40	7.67	7.40	11.93	10.80
	130	3.69	6.99	5.68	4.78	8.74	7.27	6.76	12.41	10.30
	140	3.27	7.10	5.30	4.34	9.90	6.91	6.18	12.80	9.83
	145	3.06	7.20	5.11	4.12	9.10	6.72	5.89	13.00	9.60
20	90	7.34	6.15	9.09	8.82	7.50	10.96	12.06	10.69	15.11
	100	6.72	6.67	8.62	8.15	8.14	10.47	11.20	11.65	14.52
	110	6.12	7.14	8.15	7.50	8.73	9.99	10.36	12.52	13.93
	120	5.53	7.56	7.69	6.87	9.27	9.51	9.55	13.29	13.33
	130	4.97	7.91	7.22	6.26	9.74	9.04	8.75	13.98	12.73
	140	4.46	8.20	6.79	5.71	10.20	8.60	8.04	14.60	12.20
	145	4.20	8.30	6.57	5.44	10.40	8.39	7.68	14.90	11.93
30	90	9.39	6.41	11.22	11.19	7.72	13.39	15.20	11.05	18.35
	100	8.65	7.07	10.66	10.37	8.55	12.81	14.15	12.30	17.66
	110	7.92	7.68	10.11	9.58	9.31	12.23	13.13	13.44	16.96
	120	7.21	8.24	9.56	8.81	10.01	11.66	12.13	14.49	16.26
	130	6.53	8.75	9.02	8.05	10.65	11.09	11.16	15.42	15.55
	140	5.91	9.20	8.53	7.39	11.20	10.59	10.30	16.30	14.95
	145	5.60	9.40	8.27	7.05	11.50	10.33	9.86	16.60	14.59
40	90	11.83	6.50	13.68	14.01	7.71	16.20	18.93	11.02	22.07
	100	10.94	7.31	13.03	13.02	8.74	15.51	17.67	12.61	21.26
	110	10.08	8.08	12.38	12.06	9.70	14.83	16.44	14.08	20.45
	120	9.23	8.79	11.74	11.13	10.60	14.15	15.23	15.43	19.63
	130	8.40	9.46	11.10	10.21	11.42	13.47	14.05	16.66	18.80
	140	7.67	10.10	10.54	9.42	12.20	12.89	13.02	17.80	18.09
	145	7.30	10.30	10.24	9.01	12.50	12.58	12.49	18.30	17.71
50	90	14.50	6.40	16.32	17.09	7.40	19.20	22.99	10.50	25.98
	100	13.51	7.40	15.61	15.99	8.70	18.47	21.59	12.50	25.15
	110	12.55	8.30	14.92	14.92	9.90	17.74	20.22	14.30	24.30
	120	11.61	9.20	14.22	13.87	11.00	17.01	18.88	16.00	23.44
	130	10.69	10.00	13.54	12.85	12.00	16.27	17.56	17.60	22.58
	140	9.79	10.80	12.86	11.86	13.00	15.57	16.28	19.00	21.70
	145	9.34	11.20	12.52	11.37	13.40	15.19	15.65	19.70	21.26

**LEGEND**

- Cap.** — Capacity (tons)
- kW** — Power Input
- SDT** — Saturated Discharge Temperature (F)
- SST** — Saturated Suction Temperature (F)
- THR** — Total Heat Rejection (tons)

\*Refer to compressor capacity notes, page 14.

NOTE: To ensure proper motor cooling, it is required that all 6-cylinder compressors operating with R-22 at 20 F SST or below have one of the 2 unloaders disconnected.



**COMPRESSOR CAPACITIES (Tons)\* (cont)**  
**R-22 (cont)**

SST	SDT	06EV022			06EW027			06EW033			06EW044		
		Cap.	kW	THR	Cap.	kW	THR	Cap.	kW	THR	Cap.	kW	THR
0	90	9.85	12.30	13.36	12.26	15.45	16.66	13.66	17.76	18.72	18.48	24.40	25.44
	100	9.01	12.90	12.68	11.14	16.08	15.72	12.37	18.28	17.58	17.09	25.27	24.29
	110	8.20	13.40	12.02	10.07	16.59	14.80	11.06	18.55	16.35	15.74	25.99	23.14
	120	7.41	13.90	11.38	9.05	16.97	13.88	9.75	18.55	15.04	14.42	26.55	21.98
	130	6.61	14.30	10.68	8.07	17.20	12.97	8.44	18.30	13.66	13.13	27.00	20.82
	140	5.75	14.70	9.94	7.13	17.30	12.06	7.14	17.60	12.16	11.87	27.30	19.65
	145	5.30	14.90	9.55	6.67	17.30	11.60	6.50	17.20	11.40	11.26	27.40	19.06
10	90	12.78	13.40	16.60	16.18	17.15	21.07	17.96	19.70	23.58	23.83	27.11	31.56
	100	11.75	14.20	15.80	14.79	18.12	19.96	16.49	20.69	22.38	22.13	28.42	30.23
	110	10.77	14.90	15.02	13.46	18.96	18.87	14.99	21.44	21.10	20.47	29.53	28.88
	120	9.80	15.60	14.25	12.18	19.64	17.78	13.47	21.92	19.72	18.84	30.47	27.52
	130	8.83	16.20	13.44	10.95	20.17	16.70	11.95	22.11	18.26	17.24	31.22	26.14
	140	7.81	16.80	12.60	9.77	20.50	15.61	10.44	22.00	16.71	15.68	31.80	24.74
	145	7.28	17.10	12.15	9.20	20.60	15.07	9.69	21.80	15.90	14.91	32.00	24.03
20	90	16.31	14.30	20.38	20.98	18.53	26.26	23.04	21.24	29.10	30.30	29.50	38.71
	100	15.05	15.40	19.44	19.28	19.92	24.95	21.35	22.73	27.82	28.23	31.34	37.16
	110	13.85	16.30	18.50	17.63	21.15	23.66	19.62	23.99	26.46	26.19	32.96	35.59
	120	12.68	17.20	17.58	16.05	22.20	22.37	17.87	24.99	24.99	24.20	34.35	33.99
	130	11.50	18.10	16.65	14.52	23.08	21.09	16.11	25.70	23.44	22.23	35.54	32.36
	140	10.28	18.90	15.67	13.04	23.80	19.82	14.35	26.10	21.79	20.31	36.50	30.71
	145	9.65	19.30	15.15	12.32	24.00	19.16	13.48	26.20	20.94	19.35	36.90	29.87
30	90	20.50	14.80	24.71	26.78	19.49	32.34	28.99	22.26	35.34	38.02	31.40	46.97
	100	18.99	16.20	23.60	24.71	21.35	30.79	27.04	24.30	33.97	35.52	33.87	45.17
	110	17.53	17.50	22.52	22.70	23.04	29.26	25.06	26.11	32.50	33.06	36.09	43.35
	120	16.11	18.70	21.44	20.75	24.53	27.74	23.04	27.67	30.93	30.64	38.05	41.48
	130	14.69	19.80	20.33	18.87	25.82	26.23	21.01	28.94	29.26	28.25	39.76	39.58
	140	13.24	20.90	19.20	17.04	26.90	24.71	18.97	29.90	27.49	25.90	41.20	37.64
	145	12.49	21.50	18.62	16.15	27.40	23.96	17.95	30.30	26.58	24.73	41.90	36.68
40	90	25.43	15.00	29.71	33.71	19.88	39.37	35.91	22.68	42.37	47.14	32.64	56.44
	100	23.63	16.80	28.42	31.21	22.29	37.56	33.67	25.30	40.88	44.15	35.85	54.37
	110	21.89	18.40	27.13	28.78	24.50	35.76	31.39	27.70	39.29	41.21	38.76	52.25
	120	20.18	19.90	25.86	26.42	26.50	33.98	29.08	29.85	37.58	38.30	41.38	50.09
	130	18.49	21.30	24.56	24.13	28.27	32.19	26.74	31.73	35.78	35.43	43.72	47.89
	140	16.76	22.80	23.26	21.91	29.80	30.40	24.38	33.30	33.87	32.59	45.80	45.65
	145	15.89	23.50	22.58	20.82	30.50	29.51	23.20	34.00	32.89	31.19	46.70	44.50
50	90	31.19	14.80	35.40	41.87	19.60	47.46	43.87	22.40	50.26	57.80	33.10	67.23
	100	29.05	16.90	33.87	38.89	22.60	45.34	41.32	25.60	48.61	54.26	37.10	64.84
	110	26.99	18.90	32.38	36.00	25.40	43.24	38.71	28.70	46.89	50.77	40.80	62.40
	120	24.97	20.80	30.90	33.18	28.00	41.16	36.06	31.40	45.01	47.32	44.20	59.92
	130	22.96	22.60	29.40	30.43	30.30	39.07	33.38	34.00	43.07	43.91	47.30	57.39
	140	20.93	24.30	27.86	27.76	32.40	36.99	30.68	36.20	41.00	40.54	50.00	54.79
	145	19.90	25.20	27.08	26.45	33.30	35.94	29.32	37.20	39.93	38.87	51.30	53.49

LEGEND

- Cap. — Capacity (tons)
- kW — Power Input
- SDT — Saturated Discharge Temperature (F)
- SST — Saturated Suction Temperature (F)
- THR — Total Heat Rejection (tons)

\*Refer to compressor capacity notes, page 14.

NOTE: To ensure proper motor cooling, it is required that all 6-cylinder compressors operating with R-22 at 20 F SST or below have one of the 2 unloaders disconnected.

# Performance data (cont)



## COMPRESSOR CAPACITIES (Tons)\* (cont) R-507/404A

SST	SDT	06DH3131			06DA8181			06DE8241		
		Cap.	kW	THR	Cap.	kW	THR	Cap.	kW	THR
-30	90	1.07	2.11	1.67	1.95	3.68	3.00	2.30	4.34	3.54
	100	0.92	2.09	1.52	1.76	3.78	2.84	2.04	4.36	3.28
	110	0.79	2.05	1.37	1.58	3.84	2.67	1.77	4.34	3.01
	120	0.65	1.99	1.22	1.38	3.86	2.48	1.50	4.25	2.71
	130	0.53	1.90	1.07	1.18	3.84	2.27	1.23	4.09	2.39
-20	90	1.54	2.59	2.28	2.62	4.27	3.83	3.19	5.14	4.66
	100	1.35	2.62	2.10	2.40	4.44	3.66	2.87	5.27	4.37
	110	1.17	2.63	1.92	2.17	4.58	3.47	2.54	5.34	4.07
	120	1.00	2.60	1.74	1.93	4.68	3.26	2.21	5.36	3.74
	130	0.83	2.55	1.56	1.68	4.75	3.03	1.87	5.31	3.38
-10	90	2.14	3.07	3.02	3.41	4.82	4.79	4.21	5.93	5.90
	100	1.90	3.16	2.80	3.15	5.07	4.59	3.88	6.15	5.63
	110	1.67	3.22	2.58	2.87	5.29	4.38	3.48	6.33	5.28
	120	1.44	3.24	2.36	2.58	5.48	4.14	3.07	6.46	4.91
	130	1.21	3.24	2.14	2.27	5.64	3.88	2.65	6.53	4.51
0	90	2.89	3.53	3.90	4.35	5.33	5.87	5.54	6.68	7.44
	100	2.58	3.68	3.63	4.03	5.66	5.65	5.07	7.00	7.07
	110	2.28	3.80	3.36	3.70	5.97	5.40	4.59	7.29	6.67
	120	1.99	3.89	3.10	3.34	6.25	5.12	4.09	7.53	6.24
	130	1.69	3.95	2.82	2.97	6.50	4.83	3.57	7.72	5.77
10	90	3.80	4.00	4.94	5.46	5.80	7.11	7.23	7.37	9.33
	100	3.41	4.20	4.61	5.07	6.20	6.84	6.59	7.84	8.82
	110	3.04	4.40	4.29	4.67	6.60	6.55	5.95	8.26	8.30
	120	2.67	4.50	3.95	4.25	7.00	6.24	5.30	8.60	7.75
	130	2.30	4.70	3.64	3.80	7.30	5.89	4.63	8.88	7.16
20	90	4.89	4.30	6.11	6.73	6.20	8.50	9.16	7.85	11.39
	100	4.41	4.70	5.75	6.27	6.70	8.18	8.37	8.51	10.80
	110	3.95	4.90	5.35	5.79	7.20	7.85	7.58	9.09	10.17
	120	3.50	5.20	4.98	5.30	7.60	7.46	6.77	9.61	9.51
	130	3.05	5.40	4.59	4.78	8.10	7.09	5.98	10.00	8.83

### LEGEND

- Cap. — Capacity (tons)
- kW — Power Input
- SDT — Saturated Discharge Temperature (F)
- SST — Saturated Suction Temperature (F)
- THR — Total Heat Rejection (tons)

\*Refer to compressor capacity notes, page 14.

NOTE: To ensure proper motor cooling, it is required that all 6-cylinder compressors operating with R-507/404A at -10 F SST or below have one of the 2 unloaders disconnected.



**COMPRESSOR CAPACITIES (Tons)\* (cont)**  
**R-507/404A (cont)**

SST	SDT	06DE3281			06DE5371		
		Cap.	kW	THR	Cap.	kW	THR
-30	90	2.99	5.52	4.56	4.09	7.37	6.19
	100	2.69	5.61	4.29	3.69	7.59	5.85
	110	2.37	5.61	3.97	3.30	7.77	5.51
	120	2.04	5.51	3.61	2.92	7.92	5.18
	130	1.69	5.30	3.20	2.55	8.04	4.84
-20	90	4.04	6.42	5.87	5.40	8.60	7.85
	100	3.69	6.67	5.59	4.89	8.92	7.43
	110	3.32	6.84	5.27	4.38	9.20	7.00
	120	2.93	6.93	4.91	3.89	9.44	6.58
	130	2.52	6.91	4.49	3.40	9.64	6.15
-10	90	5.27	7.20	7.32	7.03	9.85	9.83
	100	4.86	7.62	7.03	6.37	10.30	9.31
	110	4.43	7.97	6.70	5.72	10.70	8.77
	120	3.97	8.24	6.32	5.09	11.10	8.25
	130	3.47	8.41	5.87	4.46	11.40	7.71
0	90	6.71	7.83	8.94	9.02	11.10	12.18
	100	6.22	8.43	8.62	8.19	11.70	11.52
	110	5.71	8.96	8.26	7.37	12.20	10.84
	120	5.16	9.42	7.85	6.55	12.70	10.17
	130	4.57	9.80	7.36	5.75	13.20	9.51
10	90	8.37	8.30	10.74	11.41	12.20	14.89
	100	7.79	9.10	10.39	10.38	13.00	14.09
	110	7.18	9.80	9.98	9.36	13.70	13.27
	120	6.54	10.40	9.50	8.36	14.40	12.46
	130	5.86	11.00	8.99	7.36	15.00	11.64
20	90	10.29	8.50	12.71	14.26	13.20	18.02
	100	9.60	9.50	12.31	13.01	14.20	17.05
	110	8.89	10.40	11.85	11.76	15.20	16.09
	120	8.13	11.30	11.35	10.53	16.00	15.09
	130	7.33	12.10	10.78	9.31	16.80	14.10

LEGEND

- Cap. — Capacity (tons)
- kW — Power Input
- SDT — Saturated Discharge Temperature (F)
- SST — Saturated Suction Temperature (F)
- THR — Total Heat Rejection (tons)

\*Refer to compressor capacity notes, page 14.

NOTE: To ensure proper motor cooling, it is required that all 6-cylinder compressors operating with R-507/404A at -10 F SST or below have one of the 2 unloaders disconnected.

# Performance data (cont)



## COMPRESSOR CAPACITIES (Tons)\* (cont) R-507/404A (cont)

SST	SDT	06EV022			06EW027			06EW033			06EW044		
		Cap.	kW	THR	Cap.	kW	THR	Cap.	kW	THR	Cap.	kW	THR
-30	90	5.40	11.00	8.54	6.80	12.80	10.45	7.66	15.30	12.02	10.10	20.60	15.97
	100	4.80	10.90	7.90	5.94	12.70	9.56	6.79	15.10	11.09	8.98	20.60	14.85
	110	4.16	10.70	7.21	5.11	12.50	8.67	5.89	14.80	10.11	7.85	20.40	13.66
	120	3.48	10.30	6.42	4.30	12.10	7.75	4.98	14.30	9.06	6.73	20.00	12.43
	130	2.78	9.57	5.50	3.54	11.70	6.87	4.06	13.50	7.91	5.62	19.40	11.15
-20	90	7.40	13.00	11.11	9.35	15.40	13.73	10.61	18.30	15.83	13.50	24.30	20.42
	100	6.71	13.20	10.48	8.28	15.50	12.69	9.56	18.40	14.80	12.15	24.60	19.16
	110	5.98	13.30	9.77	7.23	15.40	11.62	8.48	18.30	13.70	10.79	24.70	17.83
	120	5.21	13.20	8.97	6.21	15.20	10.54	7.37	18.10	12.53	9.42	24.70	16.46
	130	4.39	12.90	8.07	5.22	14.90	9.47	6.23	17.60	11.25	8.05	24.40	15.01
-10	90	9.74	14.90	13.99	12.47	18.00	17.60	14.13	21.20	20.17	17.56	28.10	25.57
	100	8.94	15.40	13.33	11.14	18.30	16.36	12.87	21.70	19.06	15.94	28.80	24.15
	110	8.10	15.80	12.60	9.83	18.50	15.10	11.57	21.90	17.81	14.28	29.30	22.64
	120	7.20	16.00	11.76	8.55	18.50	13.82	10.23	22.00	16.50	12.61	29.60	21.05
	130	6.23	16.10	10.82	7.30	18.40	12.54	8.82	21.80	15.04	10.94	29.70	19.40
0	90	12.46	16.70	17.22	16.25	20.70	22.15	18.30	24.20	25.20	22.40	32.10	31.54
	100	11.53	17.50	16.51	14.62	21.30	20.69	16.79	24.90	23.89	20.43	33.10	29.87
	110	10.54	18.20	15.72	12.99	21.80	19.21	15.23	25.60	22.53	18.43	34.00	28.12
	120	9.48	18.70	14.80	11.39	22.00	17.66	13.60	26.00	21.01	16.39	34.70	26.28
	130	8.33	19.10	13.77	9.82	22.20	16.14	11.88	26.20	19.35	14.34	35.20	24.37
10	90	15.61	18.40	20.85	20.74	23.40	27.41	23.20	26.80	30.83	28.06	35.80	38.26
	100	14.50	19.50	20.06	18.76	24.30	25.69	21.47	28.20	29.51	25.71	37.50	36.39
	110	13.33	20.50	19.17	16.79	25.10	23.95	19.50	29.30	27.85	23.31	38.90	34.39
	120	12.09	21.20	18.13	14.84	25.70	22.17	17.56	30.00	26.11	20.87	39.90	32.24
	130	10.78	21.90	17.02	12.92	26.20	20.38	15.55	30.60	24.27	18.41	40.70	30.01
20	90	19.23	19.90	24.90	26.05	26.10	33.49	28.89	29.40	37.27	34.67	39.60	45.96
	100	17.92	21.30	23.99	23.68	27.40	31.49	26.73	31.30	35.65	31.87	41.80	43.79
	110	16.55	22.50	22.96	21.31	28.50	29.43	24.51	32.80	33.86	29.02	43.70	41.48
	120	15.10	23.50	21.80	18.96	29.50	27.37	22.21	34.00	31.90	26.13	45.10	38.98
	130	13.58	24.50	20.56	16.63	30.30	25.26	19.83	35.00	29.81	23.19	46.40	36.42

### LEGEND

- Cap. — Capacity (tons)
- kW — Power Input
- SDT — Saturated Discharge Temperature (F)
- SST — Saturated Suction Temperature (F)
- THR — Total Heat Rejection (tons)

\*Refer to compressor capacity notes.

NOTE: To ensure proper motor cooling, it is required that all 6-cylinder compressors operating with R-507/404A at -10 F SST or below have one of the 2 unloaders disconnected.

## COMPRESSOR CAPACITY NOTES

1. Compressor capacities are based on 1750 rpm and 15 F subcooling.
2. Liquid subcooling, greater than (less than) the 15 F incorporated in the ratings, increases (decreases) system capacity by 1/2 of 1% for each degree of subcooling for R-22 and increases (decreases) system capacity by 6/10 of 1% for R-134A and R-507/404A. When correcting for subcooling, power input does not change. Adjusted total heat rejection (tons) equals adjusted capacity + .285 x kW input.
3. Refrigerant temperatures shown are saturation temperatures corresponding to pressure indicated at compressor. Actual gas temperatures are higher because of superheat.
4. Capacities are based on actual suction gas temperatures to the compressor of 65 F for R-134A and R-507/404A. (This assumes superheat is obtained from liquid-suction interchanger or in evaporator.) Capacity corrections, for other than rated suction gas temperatures, may be obtained from Rating Basis and Capacity Multipliers table. R-22 ratings can be used without adjustment.



### RATING BASIS AND CAPACITY MULTIPLIERS

SST (F)	RATED SUCTION GAS TEMP (F)	ACTUAL SUCTION GAS TEMPERATURE TO COMPRESSOR (F)										
		-30	-20	-10	0	10	20	30	40	50	60	65
-30	65	.810	.830	.850	.870	.890	.910	.930	.950	.970	.990	1.000
-20			.830	.850	.870	.890	.910	.930	.950	.970	.990	1.000
-10				.850	.870	.890	.910	.930	.950	.970	.990	1.000
0					.870	.890	.910	.930	.950	.970	.990	1.000
10						.890	.910	.930	.950	.970	.990	1.000
20							.910	.930	.950	.970	.990	1.000
30								.930	.950	.970	.990	1.000
40									.950	.970	.990	1.000
50										.970	.990	1.000
										.997	.999	1.000

□ R-507/404A

■ R-134A

SST — Saturated Suction Temperature

### CAPACITY CONTROL REDUCTION STEPS\* AND PART-LOAD PERFORMANCE

UNIT 06D,06E	NO. OF CONTR CYL	% Full Load Capacity			
		100	67	49	32
		% Full Load kW			
		100	73	57	46
		Number of Active Cylinders			
ALL 4 CYLINDER MODELS	2	4	—	2	—
ALL 6 CYLINDER MODELS	4	6	4	—	2

### ARI STANDARD RATING CONDITIONS

GROUP	SST (F)	SDT (F)	RGT (F)	SUBCOOLING (F)
A (R-22)	45	130	65	15
C (R-134A)	20	120	65	15
E (R-507/404A)	-10	105	65	5

#### LEGEND

ARI — Air Conditioning and Refrigeration Institute  
 RGT — Return Gas Temperature  
 SDT — Saturated Discharge Temperature  
 SST — Saturated Suction Temperature

NOTE: Ratings are in accordance with ARI Standard 520.

\*Compressor cylinders unload in response to a self-contained suction-pressure controlled unloader valve(s) for 06D and 06E compressors. When suction pressure drops below unloader set point, cylinders unload. When suction pressure rises above cylinder load set point pressure, cylinders return to operation. Capacity control unloader set points and differential (load point - unload point) are adjustable.

### ARI STANDARD RATINGS

COMPR 06		GROUP A			GROUP C			GROUP E		
		R-22			R-134A			R-507/404A		
		Cap.	kW	THR	Cap.	kW	THR	Cap.	kW	THR
D	A8081	3.28	3.40	4.23	—	—	—	—	—	—
	H3131	5.12	5.20	6.61	1.84	2.60	2.58	1.69	3.20	2.60
	A8181	7.46	7.60	9.63	3.02	4.00	4.17	2.86	5.20	4.33
	E8241	9.51	9.80	12.29	3.79	5.00	5.20	3.49	6.20	5.27
	E3281	11.49	11.70	14.83	4.67	6.20	6.43	4.41	7.80	6.63
	E5371	15.76	17.20	20.64	6.43	8.40	8.83	5.74	10.50	8.73
E	V022	20.72	22.00	26.97	6.95	9.60	9.68	8.09	15.70	12.56
	W027	27.26	29.30	35.60	9.05	12.40	12.58	9.95	18.40	15.20
	W033	30.06	32.90	39.43	11.05	15.00	15.30	11.61	21.90	17.83
	W044	39.66	45.60	52.61	14.82	21.00	20.79	14.35	29.10	22.64

#### LEGEND

Cap. — Capacity (tons)  
 kW — Power Input  
 THR — Total Heat Rejection (tons)

NOTE: Ratings are in accordance with ARI Standard 520.

# Electrical data



## COMPRESSOR MOTOR\*

COMPRESSOR MOTOR PART NUMBER 06D		VOLTAGE (3 Ph-60 Hz)	HP	MCC	RLA	LRA	MOTOR WINDING RESISTANCE (Ohms)
M	808	575	3	7	5	28.4	5.0
		208/230		17.4	12.4	71	0.78
460	8.7	6.2		35.5	3.1		
	313	575	5	10.8	7.7	40	3.3
		208/230		27	19.3	100	0.5
460	13.5	9.6		50	2.1		
A	818	575	6.5	17.6	12.6	64	2.6
		208/230		44	31.4	160	0.42
	460	22		15.7	80	1.7	
	824	575	7.5	22.2	15.9	79	2.0
208/230		55.5		39.6	198	0.31	
460	27.8	19.8		99	1.3		
328	575	10	25	17.9	91	1.7	
	208/230		62	44.3	228	0.26	
460	31		22.1	114	1.0		
537	575	15	32	22.9	96	1.2	
	208/230		89	63.6	266	0.18	
460	40		28.6	120	0.72		

### LEGEND

- LRA** — Locked Rotor Amps  
**MCC** — Maximum Continuous Current  
**RLA** — Rated Load Amps

\*Refer to physical data table to match compressor motor with correct compressor unit.

### NOTES:

1. RLA (rated load amps) value shown is:  $MCC \div 1.40 = RLA$ .
2. For minimum contactor sizing, use RLA value determined by:  $MCC \div 1.40 = RLA$ .

3. For wiring sizing, the RLA value can be determined by:  $MCC \div 1.56 = RLA$ .
4. Compressor operating amps at any specific conditions can only be determined from a performance curve.
5. RLA values for 06D compressor protected by a calibrated circuit breaker will depend on must-trip value of circuit breaker.
6. Ohm values shown for resistance are approximate and shown for reference only. Motors from different vendors and motors of different efficiencies can differ up to 15% from data shown.
7. Electrical data for motor part numbers 06DR and 50 Hz units (not shown) are available from Carrier Sales Representative.

### ALLOWABLE OPERATING RANGES

NOMINAL VOLTAGE	MAXIMUM	MINIMUM
208/230	254	187
460	529	414
575	661	518



**COMPRESSOR MOTOR WITH CIRCUIT BREAKER\***

Compressor Motor Part Number 06E	COMPRESSOR MOTOR DATA							CIRCUIT BREAKER					
	Voltage (3 Ph - 60 Hz)	Hp	Maximum Must Trip Amps	Maximum RLA	LRA-XL	LRA-PW (first winding)	Motor Winding Resistance (Ohms)	Recommended Circuit Breaker Part No.	MHA	MTA	LRA	Recommended RLA	
A	250	208/230	20	108	87	345	207	0.32	HH83XB336 XA461 XA424	91	104	350	74.3
		575		45	36	120	72	2.2		33	38	124	27.1
		460		54	44	173	104	1.3		42	49	175	35
	265	208/230	25	140	112	446	268	0.27	HH83XC509 XA469 XA426	110	127	420	90.7
		575		57	46	164	98	1.6		46	53	164	37.9
		460		70	56	223	134	1.1		55	643	210	45.7
	275	208/230	30	168	135	506	304	0.22	HH83XC539 XA430 XA425	142	163	507	116.4
		575		65	52	176	106	1.3		50	58	168	41.4
		460		84	68	253	152	0.9		63	73	210	52.1
	299	208/230	40	236	189	690	414	0.15	HH83XC537 XA551 XA550	187	215	636	153.6
		575		94	75	276	165	21		74	85	236	60.7
		460		118	95	345	207	0.58		92	106	295	75.7

**LEGEND**

- LRA** — Locked Rotor Amps
- MHA** — Must Hold Amps
- MTA** — Must-Trip Amps
- PW** — Part-Winding (Start)
- RLA** — Rated Load Amps
- XL** — Across-the-Line (Start)

\*Refer to physical data table to match compressor motor with correct compressor unit.

**NOTES:**

1. Compressor MTA and RLA values are maximum figures.
2. LRA values for PW second winding = 1/2 the LRA – XL value.
3. 3-Pole XL circuit breakers shown, other 3-Pole XL alternates and 6-Pole PW breakers available. Terminal lugs for circuit breakers available in package 06EA660152 (not shown).

4. Recommended RLA value shown is determined by: circuit breaker must trip value ÷ 1.40. Use this recommended (and minimum) RLA value to determine nameplate stamping, minimum contactor sizing, and wire sizing. **RECOMMENDED RLA FOR 06E COMPRESSORS EQUALS: MUST-TRIP (MTA) OF CARLYLE APPROVED OVERCURRENT DEVICE BEING USED ÷ 1.40**
5. Compressor operating amps at any specific condition can only be determined from a performance curve.
6. Ohm values for resistance are approximate and shown for reference purposes only. Motors from different vendors and motors of different efficiencies can differ up to 15% from data shown.
7. Electrical data for motor part numbers 06ER, 06EM and 50 Hz units (not shown) are available from Carrier Sales Representative.

**ALLOWABLE OPERATING RANGES**

NOMINAL VOLTAGE	MAXIMUM	MINIMUM
208/230	254	187
460	529	414
575	661	518



### CONTROL CIRCUIT WIRING FOR 06E UNITS

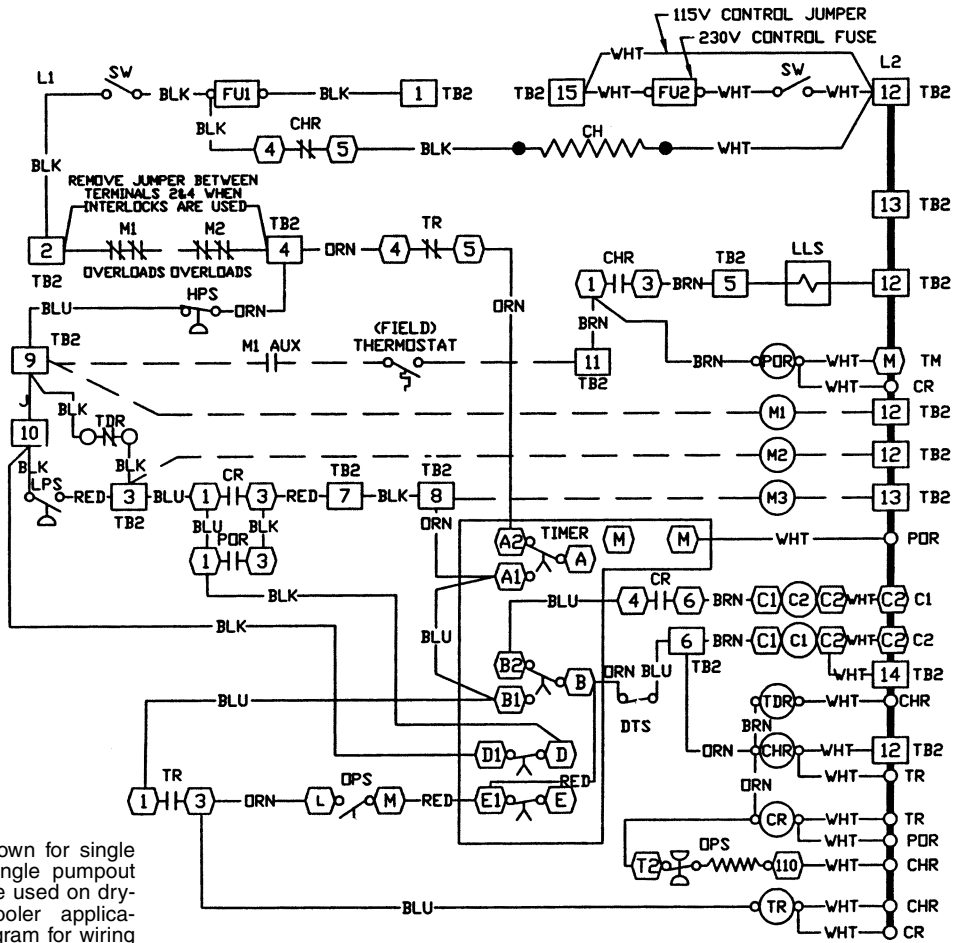

# Typical wiring schematics (cont)



## LEGEND AND NOTES FOR TYPICAL WIRING SCHEMATICS 06D AND 06E

### LEGEND

<b>AUX</b>	—	Auxiliary
<b>C</b>	—	Compressor Contactor
<b>C1</b>	—	Compressor Contactor (XL start and first step of PW start)
<b>C2</b>	—	Compressor Contactor (PW second step)
<b>CH</b>	—	Crankcase Heater
<b>CHR</b>	—	Crankcase Heater Relay
<b>COMP</b>	—	Compressor Motor Wiring
<b>CR</b>	—	Control Relay
<b>DTS</b>	—	Discharge Temperature Sensor
<b>DX</b>	—	Direct Expansion
<b>EQUIP</b>	—	Equipment
<b>FU</b>	—	Fuse
<b>GND</b>	—	Ground
<b>HPS</b>	—	High-Pressure Switch
<b>IP</b>	—	Internal Protector
<b>LLS</b>	—	Liquid Line Solenoid Valve
<b>LPS</b>	—	Low-Pressure Switch
<b>M1</b>	—	Evaporator Fan or Chilled Water Pump
<b>M2</b>	—	Cooling Tower pump
<b>M3</b>	—	Cooling Tower Fan
<b>NEC</b>	—	National Electrical Code
<b>OL</b>	—	Overload
<b>OPS</b>	—	Oil-Pressure Switch

<b>POR</b>	—	Pumpout Relay
<b>SW</b>	—	Start-Stop-Reset Switch
<b>TB</b>	—	Terminal Block
<b>TDR</b>	—	Time Delay Relay
<b>TM</b>	—	Timer Motor
<b>TR</b>	—	Timer Relay
	—	Terminal Block Connector
	—	Unmarked Terminal
	—	Unmarked Terminal
	—	Marked Terminal
	—	Factory Wiring
	—	Field Control Wiring
	—	To indicate common potential only; not to represent wiring.
	—	Splice

### NOTES:

1. Factory wiring is in compliance with NEC. Any field modifications or additions must be in compliance with all applicable codes. Use copper, copper-clad aluminum for field power supply only.
2. Field power supply wiring must be 75 C minimum.
3. Compressor thermally protected. Three-phase motors are protected against primary single-phasing condition.
4. Pilot duty control must be field supplied. Minimum contact rating must be 25 va.
5. 60 Hz units have 120 volt control circuit. 50 Hz units have 230 volt control circuit. A separate source of supply at the correct voltage must be field supplied supply at the through a fused disconnect

device with a maximum rating of 15 A to TB2 connections **L1**

(Hot Side) and **L2** (Neutral).

6. Open control circuit disconnect switch for servicing only. Disconnect must remain closed for crankcase heater to operate.
7. A transformer of the following rating may be field supplied for 60 Hz units: 350 va.
8. Transformer must be fused and grounded per applicable codes.
9. If any of the original wiring furnished must be replaced, it must be replaced with 90 C wire or its equivalent.

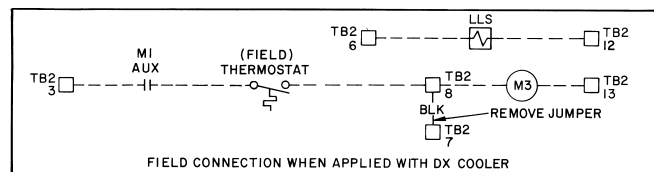

# Typical piping and wiring

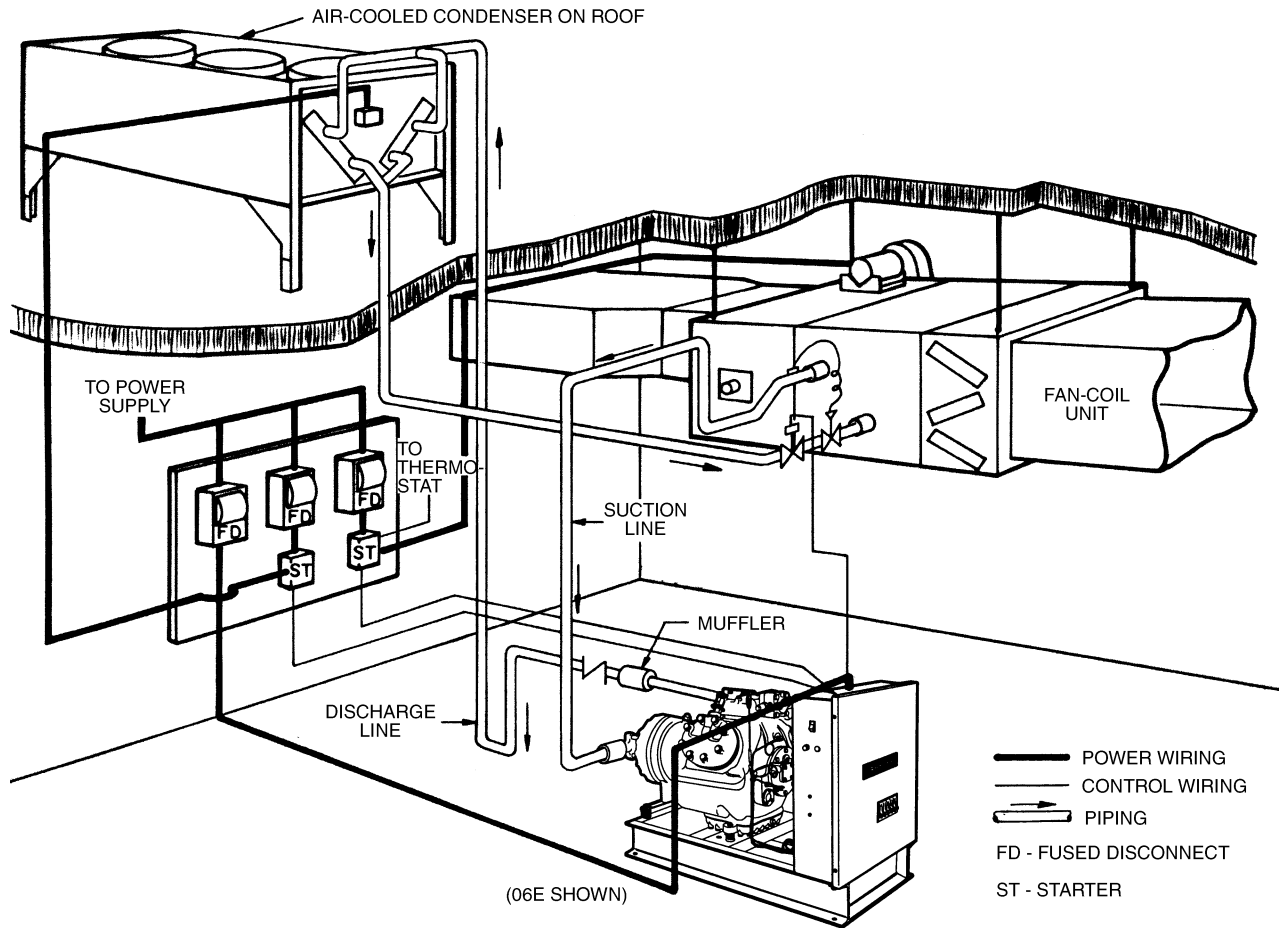

**NOTES:**

1. Wiring and piping shown are general points-of-connection guides only and are not intended to include all details for a specific installation.
2. All wiring must comply with applicable local and national codes.
3. All piping must follow standard refrigerant piping techniques. Refer to Carrier System Design Manual for details.
4. On all remote condenser units, a discharge line check valve is required and located after the muffler, as close to the compressor as possible.

# Application data



**Adequate lubrication** depends on proper oil return to compressor (especially during unloaded operation) and keeping liquid refrigerant out of crankcase (refrigerant dilutes oil).

**Correct system piping design** prevents gravity flow of refrigerant to compressor while permitting oil return. Refer to Carrier System Design Manual for correct refrigerant piping techniques.

**Crankcase heater** energized and Liquid Line Solenoid closed during shutdown periods restrict refrigerant migration to compressor and absorption of refrigerant by the oil (minimum protection). A discharge line check valve prevents refrigerant migration from condenser to compressor and should be installed on air cooled applications where condenser or receiver ambient temperature is at or above compressor ambient temperature.

**Single pumpout control** incorporates a liquid line solenoid valve and prevents refrigerant migration by allowing unit to shut off only after all refrigerant has been removed from evaporator. (Compressor shuts off on low-pressure cutout.)

**Automatic pumpdown control** allows compressor to cycle on for short intervals during normally "off" periods. This periodically removes any refrigerant from evaporator which may have accumulated.

This control should not be used with 06D or 06E compressors having cylinder head unloaders.

**Dry-expansion cooler applications** (excluding brine) should not incorporate single pumpout or automatic pump-down control. Crankcase heater and liquid line solenoid (minimum protection) are recommended for these applications.

**Compressors** located in a space subject to low-ambient temperatures require special provision for proper operation during start-up. (Low-ambient temperatures cause compressor to operate at abnormally low suction pressures during start-up.)

Proper operation can be maintained by:

1. Heating the space,
2. A time-delay relay installed to bypass the low-pressure control during start-up, or
3. Use of a suction temperature control to operate compressor, instead of low-pressure control.

# Guide specifications



## 06D and 06E Semi-Hermetic Reciprocating Compressor Unit

### HVAC Guide Specifications

Size Range: **3 to 15 tons**

Carrier Part Number: **06D**

Size Range: **20 to 40 tons**

Carrier Part Number: **06E**

#### Part 1 — General

##### 1.01 SYSTEM DESCRIPTION

Reciprocating type, semi-hermetic refrigerant compressor for use with refrigerants R-22, R134A, or R-507/404A.

##### 1.02 QUALITY ASSURANCE

- A. Unit performance shall be rated according to ARI 520 latest edition and comply with ANSI/ASHRAE 15 safety code, NEC, and ASME Code.
- B. Compressors will be factory run tested to ensure proper performance.

##### 1.03 DELIVERY, STORAGE AND HANDLING

Unit will be stored and handled according to manufacturer's instructions.

#### Part 2 — Products

##### 2.01 EQUIPMENT

###### A. General:

Factory assembled single piece, refrigerant compressor unit. Contained within the package shall be a semi-hermetic reciprocating compressor, structural steel base, control panel, power terminal box, wiring, piping, and controls required prior to field start-up.

###### B. Compressors:

Reciprocating semi-hermetic type only, with shutoff valves, automatically reversible positive displacement oil pump, oil charge, crankcase heater with relay, and suction pressure actuated cylinder unloaders. Unit mounted on vibration isolators.

##### C. Controls and Safeties:

- 1. Included in the control panel are power and control terminal blocks, contactors, control relays, on/off switch, and unit designed to start with con-trolled cylinders unloaded. Factory assembled control box to be tested and mounted on structural base.
- 2. Safeties in the control box include high- and low-pressure switches, timer to prevent compressor short cycling, overload relays or circuit breakers, and control circuit fuse.

##### D. Electrical Requirements:

All control and power wiring between control box and compressor shall be factory assembled.

##### E. Special Features:

Certain standard features are removed and replaced by those features designated by \* below. Consult your local Carrier sales office for amending specifications.

###### \* 1. Electric Actuated Unloaders:

Includes all necessary hardware to allow field conversion from suction pressure actuated to electric solenoid actuated unloaders.

###### \* 2. Water-Cooled Condenser:

Multipass shell and tube with integral finned copper tubes for field installation. Shall be factory tested to comply with ASME Code for unfired pressure vessels, ARI Standard 450 for condensers, and ANSI/ASHRAE safety code. Equipped with pressure relief, liquid line shutoff, and connection for water regulating valve.

###### \* 3. Discharge Muffler:

Field installed discharge line muffler for noise reduction.



**Manufacturer reserves the right to discontinue, or change at any time, specifications or designs without notice and without incurring obligations.**