



# Installation Instructions



**Comfort**  
SERIES

A05341

**Fig. 1 – — 24ACA**

**NOTE:** Read the entire instruction manual before starting the installation.

## TABLE OF CONTENTS

	PAGE
<b>SAFETY CONSIDERATIONS</b> .....	2
<b>INSTALLATION RECOMMENDATIONS</b> .....	2
<b>INSTALLATION</b> .....	3 - 9
Step 1 - Check Equipment & Jobsite .....	3
Step 2 - Install on Solid Pad .....	3
Step 3 - Clearance Requirements .....	3
Step 4 - Operating Ambient .....	3
Step 5 - Install TXV .....	3 - 4
Step 6 - Make Piping Connections .....	4 - 7
Step 7 - Make Electrical Connections .....	7 - 8
Step 8 - Compressor Crankcase Heater .....	8
Step 9 - Install Electrical Accessories .....	8
Step 10 - Start-Up .....	8 - 9
Step 11 - Check Charge .....	9
Step 12 - Final Checks .....	9
<b>TECH ASSIST™ DIAGNOSTICS AT-A-GLANCE</b> ....	10
<b>CARE AND MAINTENANCE</b> .....	11
<b>PURON® QUICK REFERENCE GUIDE</b> .....	12

## SAFETY CONSIDERATIONS

Improper installation, adjustment, alteration, service, maintenance, or use can cause explosion, fire, electrical shock, or other conditions which may cause death, personal injury, or property damage. Consult a qualified installer, service agency, or your distributor or branch for information or assistance. The qualified installer or agency must use factory-authorized kits or accessories when modifying this product. Refer to the individual instructions packaged with the kits or accessories when installing.

Follow all safety codes. Wear safety glasses, protective clothing, and work gloves. Use quenching cloth for brazing operations. Have fire extinguisher available. Read these instructions thoroughly and follow all warnings or cautions included in literature and attached to the unit. Consult local building codes and National Electrical Code (NEC) for special requirements.

Recognize safety information. This is the safety-alert symbol . When you see this symbol on the unit and in instructions or manuals, be alert to the potential for personal injury. Understand these signal words; DANGER, WARNING, and CAUTION. These words are used with the safety-alert symbol. DANGER identifies the most serious hazards which **will** result in severe personal injury or death. WARNING signifies hazards which **could** result in personal injury or death. CAUTION is used to identify unsafe practices which **would** result in minor personal injury or product and property damage. NOTE is used to highlight suggestions which **will** result in enhanced installation, reliability, or operation.

24ACA



## WARNING

### ELECTRICAL SHOCK HAZARD

Failure to follow this warning could result in personal injury or death.

Before installing, modifying, or servicing system, main electrical disconnect switch must be in the OFF position. There may be more than 1 disconnect switch. Lock out and tag switch with a suitable warning label.



## WARNING

### UNIT OPERATION AND SAFETY HAZARD

Failure to follow this warning could result in personal injury or equipment damage.

Puron® systems operate at higher pressures than standard R-22 systems. To avoid damage to the unit or possible personal injury, do not use R-22 service equipment or components on Puron equipment.

## INSTALLATION RECOMMENDATIONS

**NOTE:** In some cases noise in the living area has been traced to gas pulsations from improper installation of equipment.

1. Locate unit away from windows, patios, decks, etc. where unit operation sound may disturb customer.
2. Ensure that vapor and liquid tube diameters are appropriate for unit capacity.
3. Run refrigerant tubes as directly as possible by avoiding unnecessary turns and bends.
4. Leave some slack between structure and unit to absorb vibration.
5. When passing refrigerant tubes through the wall, seal opening with RTV or other pliable silicon-based caulk. (See Fig. 2.)
6. Avoid direct tubing contact with water pipes, duct work, floor joists, wall studs, floors, and walls.
7. Do not suspend refrigerant tubing from joists and studs with a rigid wire or strap which comes in direct contact with tubing. (See Fig. 2.)
8. Ensure that tubing insulation is pliable and completely surrounds vapor tube.
9. When necessary, use hanger straps which are 1 in. wide and conform to shape of tubing insulation. (See Fig. 2.)
10. Isolate hanger straps from insulation by using metal sleeves bent to conform to shape of insulation.

**NOTE:** Avoid contact between tubing and structure

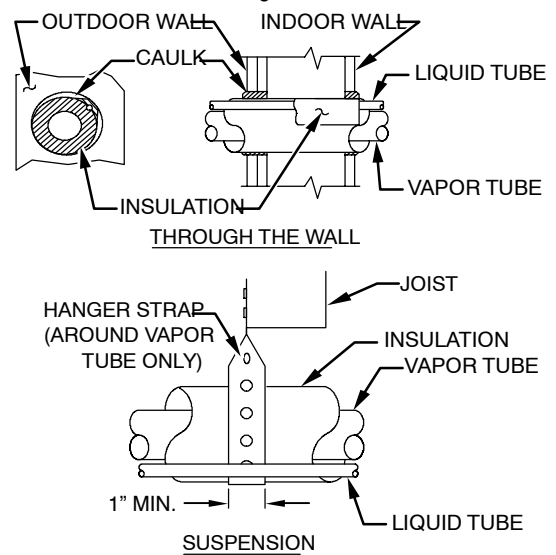

**Fig. 2 — Connecting Tube Installation**

A94026

Outdoor unit contains system refrigerant charge for operation with ARI rated indoor unit when connected by 15 ft. of field-supplied or factory accessory tubing. For proper unit operation, check refrigerant charge using charging information located on control box cover and/or in the Check Charge section of this instruction.

**IMPORTANT:** Maximum liquid-line size is 3/8-in. OD for all residential applications including long line.

**IMPORTANT:** Always install the factory-supplied liquid-line filter drier. If replacing the filter drier, refer to Product Data Digest for appropriate part number. Obtain replacement filter driers from your distributor or branch.

## INSTALLATION

Specifications for this unit in residential new construction market require the outdoor unit, indoor unit, refrigerant tubing sets, metering device, and filter drier listed in presale literature. There can be no deviation. Consult the Application Guideline and Service Manual – Air Conditioners and Heat Pumps Using Puron® Refrigerant to obtain required unit changes for specific applications and for R-22 retrofit.

### STEP 1. —Check Equipment and Job Site

#### UNPACK UNIT

Move to final location. Remove carton taking care not to damage unit.

#### INSPECT EQUIPMENT

File claim with shipping company prior to installation if shipment is damaged or incomplete. Locate unit rating plate on unit corner panel. It contains information needed to properly install unit. Check rating plate to be sure unit matches job specifications.

### STEP 2. —Install on a Solid, Level Mounting Pad

If conditions or local codes require the unit be attached to pad, tie down bolts should be used and fastened through knockouts provided in unit base pan. Refer to unit mounting pattern in Fig. 3 to determine base pan size and knockout hole location.

For hurricane tie downs - contact your local distributor for details and PE (Professional Certification), if required by local authorities.

On rooftop applications, mount on level platform or frame. Place unit above a load-bearing wall and isolate unit and tubing set from structure. Arrange supporting members to adequately support unit and minimize transmission of vibration to building. Consult local codes governing rooftop applications.

Roof mounted units exposed to winds may require wind baffles. Consult the Application Guideline and Service Manual - Residential Split System Air Conditioners and Heat Pumps Using Puron® Refrigerant for wind baffle construction.

**NOTE:** Unit must be level to within  $\pm 2^\circ$  ( $\pm 3/8$  in./ft.) per compressor manufacturer specifications.

### STEP 3. —Clearance Requirements

When installing, allow sufficient space for airflow clearance, wiring, refrigerant piping, and service. Allow 30-in. clearance to service end of unit and 48 in. above unit. For proper airflow, a 6-in. clearance on 1 side of unit and 12 in. on all remaining sides must be maintained. Maintain a distance of 24 in. between units. Position so water, snow, or ice from roof or eaves cannot fall directly on unit.

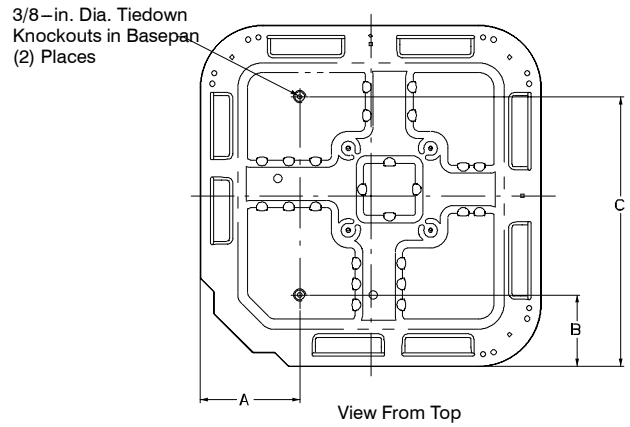

UNIT BASE PAN DIMENSIONS	TIEDOWN KNOCKOUT LOCATIONS		
	A	B	C
26 X 26	9-1/8	4-7/16	21-1/4
31-1/2 X 31-1/2	9-1/8	6-9/16	24-11/16
35 X 35	9-1/8	6-9/16	28-7/16

A05177

**Fig. 3 — Tiedown Knockout Locations**

On rooftop applications, locate unit at least 6 in. above roof surface.

### STEP 4. —Operating Ambient

The minimum outdoor operating ambient in cooling mode is 55°F, and the maximum outdoor operating ambient in cooling mode is 125°F.

### STEP 5. —Install TXV

**NOTE:** Applies to non-TXV and R-22 TXV indoor units only. If installing a rated and approved indoor coil without a factory installed Puron® TXV, remove and replace the fixed orifice or R-22 TXV expansion device with a hard shutoff Puron TXV.

The thermostatic expansion valve is specifically designed to operate with Puron. Do not use an R-22 TXV. An existing R-22 TXV must be replaced with a factory-approved TXV specifically designed for Puron. Refer to Product Data Sheet for the appropriate TXV kit number.

⚠

## CAUTION

**UNIT OPERATION HAZARD**

Failure to follow this caution may result in equipment damage or improper operation.

To avoid improper performance and possible equipment failure, all indoor coil units must be installed with a hard shut off Puron® TXV metering device.

**IMPORTANT:** The TXV should be mounted as close to the indoor coil as possible and in a vertical, upright position. Avoid mounting the inlet tube vertically down. Valve is more susceptible to malfunction due to debris if inlet tube is facing down. A factory-approved filter drier must be installed in the liquid line.

24ACA

## Installing TXV in Place of Piston

1. Pump system down to 2 psig and recover refrigerant.
2. Remove hex nut from piston body. Use backup wrench on fan coils.
3. Remove and discard factory-installed piston. Be sure Teflon seal is in place.
4. Reinstall hex nut. Finger tighten nut plus 1/2 turn.

**NOTE:** If the piston is not removed from the body, TXV will not function properly.



## CAUTION

### EQUIPMENT DAMAGE HAZARD

Failure to follow this caution may result in equipment damage or improper operation.

To prevent damage to the unit, use a brazing shield and wrap TXV with wet cloth or use heat sink material.

5. Install TXV on indoor coil liquid line. Sweat swivel adapter to inlet of indoor coil and attach to TXV outlet. Use backup wrench to avoid damage to tubing or valve. Sweat inlet of TXV, marked "IN" to liquid line. Avoid excessive heat which could damage valve.
6. Install vapor elbow with equalizer adapter to suction tube of line set and suction connection to indoor coil. Adapter has a 1/4-in. male connector for attaching equalizer tube.
7. Connect equalizer tube of TXV to 1/4-in. equalizer fitting on vapor line adapter.
8. Attach TXV bulb to horizontal section of suction line using clamps provided. Insulate bulb with field-supplied insulation tape. See Fig. 4 for correct positioning of sensing bulb.
9. Proceed with remainder of unit installation.

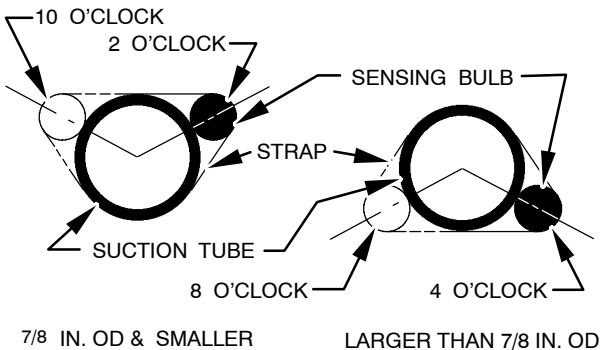

**Fig. 4 — Position of Sensing Bulb**

A81032

## Replacing TXV on R-22 Indoor Coil

1. Pump system down to 2 psig and recover refrigerant.
2. Remove coil access panel and fitting panel from front of cabinet.
3. Remove TXV support clamp using a 5/16-in. nut driver. Save the clamp.
4. Remove R-22 TXV using a backup wrench on flare connections to prevent damage to tubing.
5. Using wire cutters, cut equalizer tube off flush with vapor tube inside cabinet.
6. Remove bulb from vapor tube inside cabinet.
7. Braze equalizer stub-tube closed. Use protective barrier as necessary to prevent damage to drain pan.

**IMPORTANT:** Route the equalizer tube of Puron TXV through suction line connection opening in fitting panel prior to replacing fitting panel around tubing.

8. Install TXV with 3/8-in. copper tubing through small hole in service panel. Use wrench and backup wrench, to avoid damage to tubing or valve, to attach TXV to distributor.
9. Reinstall TXV support clamp (removed in item 3).
10. Attach TXV bulb to vapor tube inside cabinet, in same location as original was when removed, using supplied bulb clamps (nylon or copper). See Fig. 4 for correct positioning of sensing bulb.
11. Route equalizer tube through suction connection opening (large hole) in fitting panel and install fitting panel in place.
12. Sweat inlet of TXV, marked "IN" to liquid line. Avoid excessive heat which could damage valve.
13. Install vapor elbow with equalizer adapter to vapor line of line set and vapor connection to indoor coil. Adapter has a 1/4-in. male connector for attaching equalizer tube.
14. Connect equalizer tube of TXV to 1/4-in. equalizer fitting on vapor line adapter. Use backup wrench to prevent damage to equalizer fitting.
15. Proceed with remainder of unit installation.

**STEP 6. —Make Piping Connections**

**⚠ WARNING**

**PERSONAL INJURY AND ENVIRONMENTAL HAZARD**

Failure to follow this warning could result in personal injury or death.

Relieve pressure and recover all refrigerant before system repair or final unit disposal to avoid personal injury or death. Use all service ports and open all flow-control devices, including solenoid valves.

**⚠ CAUTION**

**UNIT DAMAGE HAZARD**

Failure to follow this caution may result in equipment damage or improper operation.

To prevent improper performance and/or unit component failures, do not leave system open to atmosphere any longer than minimum required for installation. POE oil in compressor is extremely susceptible to moisture absorption. Always keep ends of tubing sealed during installation.

**⚠ CAUTION**

**UNIT DAMAGE HAZARD**

Failure to follow this caution may result in equipment damage or improper operation.

If ANY refrigerant tubing is buried, provide a 6 in. vertical rise at service valve. Refrigerant tubing lengths up to 36 in. may be buried without further special consideration. Do not bury lines longer than 36 in.

**⚠ CAUTION**

**UNIT DAMAGE HAZARD**

Failure to follow this caution may result in equipment damage or improper operation.

To prevent damage to unit or service valves observe the following:

- Use a brazing shield.
- Wrap service valves with wet cloth or use a heat sink material.

Outdoor units may be connected to indoor section using accessory tubing package or field-supplied refrigerant grade tubing of correct size and condition. Rated tubing diameters shown in Table 1 recommended up to 80 ft. See Product Data for acceptable alternate vapor diameters and associated capacity losses. For tubing requirements beyond 80 ft., substantial capacity and performance losses can occur. Following the recommendations in the Longline Guideline - Residential Split-System Air Conditioners and Heat Pumps Using Puron® Refrigerant will reduce these losses. Refer to Table 1 for field tubing diameters. Refer to Table 2 for accessory requirements.

There are no buried-line applications greater than 36 in.

If refrigerant tubes or indoor coil are exposed to atmosphere, they must be evacuated to 500 microns to eliminate contamination and moisture in the system.

**OUTDOOR UNIT CONNECTED TO FACTORY-APPROVED INDOOR UNIT:**

Outdoor unit contains correct system refrigerant charge for operation with factory approved ARI rated indoor unit when connected by 15 ft. of field-supplied or factory-accessory tubing, and factory supplied filter drier. Check refrigerant charge for maximum efficiency.

**24ACA**

**Table 1—Refrigerant Connections and Recommended Liquid and Vapor Tube Diameters (In.)**

UNIT SIZE	LIQUID		RATED VAPOR (up to 80 ft. *)	
	Connection Diameter	Tube Diameter	Connection Diameter	Tube Diameter
<b>018, 024</b>	3/8	3/8	5/8	5/8
<b>030, 036</b>	3/8	3/8	3/4	3/4
<b>042, 048</b>	3/8	3/8	7/8	7/8
<b>060</b>	3/8	3/8	7/8	1-1/8

**Notes:**

1. Tube diameters are for total equivalent lengths up to 80 ft.
2. Do not apply capillary tube or fixed orifice indoor coils to these units.

\* For Tubing Set lengths between 80 and 200 ft. horizontal or 20 ft. vertical differential (250 ft. Total Equivalent Length), refer to the Longline Guideline— Air Conditioners and Heat Pumps using Puron.

**Table 2—Accessory Usage**

Accessory	REQUIRED FOR LOW-AMBI- ENT APPLICATIONS (Below 55 °F)	REQUIRED FOR LONG LINE APPLICATIONS* (Over 80 Ft.)	REQUIRED FOR SEA COAST APPLICATIONS (Within 2 miles)
Crankcase Heater	Yes	Yes	No
Evaporator Freeze Thermostat	Yes	No	No
Winter Start Control	Yes †	No	No
Accumulator	No	No	No
Compressor Start Assist Capacitor and Relay	Yes	Yes	No
Motor Master® Control or Low-ambient Pressure Switch	Yes	No	No
Support Feet	Recommended	No	Recommended
Liquid Line Solenoid Valve	No	See Long-Line Application Guideline	No
Ball Bearing Fan Motor	Yes ‡	No	No

\* For Tubing Set lengths between 80 and 200 ft. horizontal or 20 ft. vertical differential (250 ft. Total Equivalent Length), refer to the Longline Guideline – Air Conditioners and Heat Pumps using Puron®  
 †Required for low-ambient controller (full modulation feature) and Motor Master® control only.  
 ‡Required for low-ambient controller (full modulation feature) and Motor Master® control only.

**INSTALL LIQUID-LINE FILTER DRIER INDOOR**

**⚠ CAUTION**

**UNIT DAMAGE HAZARD**

Failure to follow this caution may result in equipment damage or improper operation.

To avoid performance loss and compressor failure, installation of filter drier in liquid line is required.

**⚠ CAUTION**

**UNIT DAMAGE HAZARD**

Failure to follow this caution may result in equipment damage or improper operation.

To avoid filter drier damage while brazing, filter drier must be wrapped in a heat-sinking material such as a wet cloth.

Refer to Fig. 5 and install filter drier as follows:

1. Braze 5-in. liquid tube to the indoor coil.
2. Wrap filter drier with damp cloth.
3. Braze filter drier to above 5” liquid tube. Flow arrow must point towards indoor coil.
4. Connect and braze liquid refrigerant tube to the filter drier.

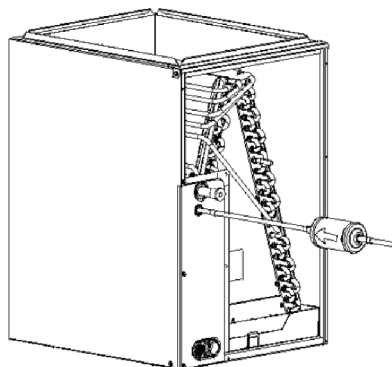

**Fig. 5 – — Liquid Line Filter Drier**

A05178

Connect vapor tube to fitting on outdoor unit vapor service valves (see Table 1.) Connect and braze the 3/8” coupling (provided with the filter drier) to the liquid service valve and connect and braze the liquid tubing to the other end of this coupling. Use refrigerant grade tubing.

**SWEAT CONNECTION**

**⚠ CAUTION**

**UNIT DAMAGE HAZARD**

Failure to follow this caution may result in equipment damage or improper operation.

To avoid valve damage while brazing, service valves must be wrapped in a heat-sinking material such as a wet cloth.

Service valves are closed from factory and ready for brazing. After wrapping service valve with a wet cloth, braze sweat connections using industry accepted methods and materials. Consult local code requirements. Refrigerant tubing and indoor coil are now ready for leak testing. This check should include all field and factory joints.

**EVACUATE REFRIGERANT TUBING AND INDOOR COIL**

**⚠ CAUTION**

**UNIT DAMAGE HAZARD**

Failure to follow this caution may result in equipment damage or improper operation.

To avoid compressor damage, never use the system compressor as a vacuum pump.

Refrigerant tubes and indoor coil should be evacuated using the recommended deep vacuum method of 500 microns. The alternate triple evacuation method may be used if the procedure outlined below is followed. Always break a vacuum with dry nitrogen.

**REFRIGERANT TUBING CONNECTION OUTDOOR**

24ACA

## Deep Vacuum Method

The deep vacuum method requires a vacuum pump capable of pulling a vacuum of 500 microns and a vacuum gage capable of accurately measuring this vacuum depth. The deep vacuum method is the most positive way of assuring a system is free of air and liquid water. (See Fig. 6)

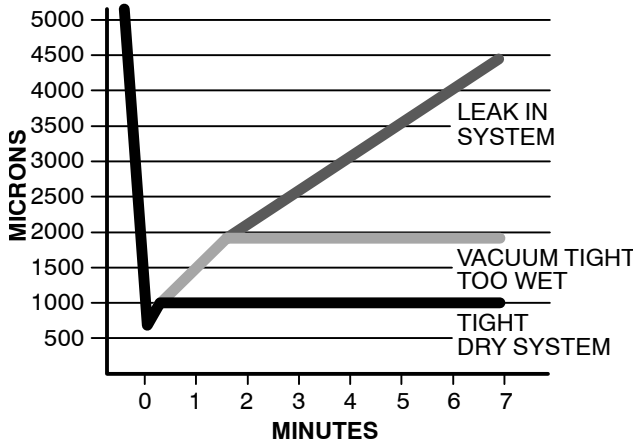

Fig. 6 — Deep Vacuum Graph

A95424

## Triple Evacuation Method

The triple evacuation method should only be used when vacuum pump is only capable of pumping down to 28 in. of mercury vacuum and system does not contain any liquid water. Refer to Fig. 7 and proceed as follows:

1. Pump system down to 28 in. of mercury and allow pump to continue operating for an additional 15 minutes.
2. Close service valves and shut off vacuum pump.
3. Connect a nitrogen cylinder and regulator to system and open until system pressure is 2 psig.
4. Close service valve and allow system to stand for 1 hr. During this time, dry nitrogen will be able to diffuse throughout the system absorbing moisture.
5. Repeat this procedure as indicated in Fig. 7. System will then be free of any contaminants and water vapor.

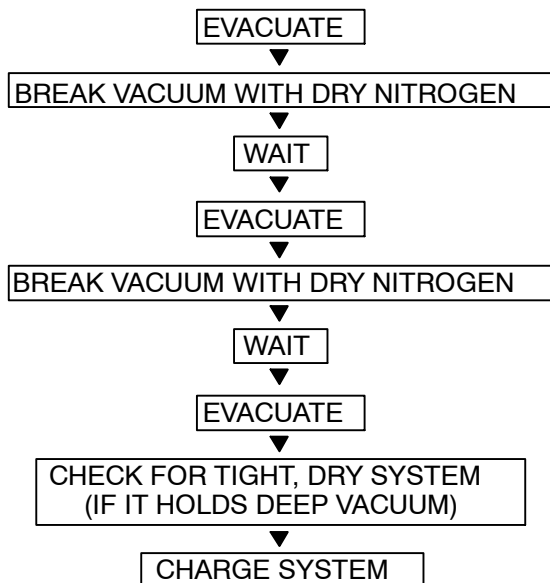

Fig. 7 — Triple Evacuation Method

A95425

## FINAL TUBING CHECK

**IMPORTANT:** Check to be certain factory tubing on both indoor and outdoor unit has not shifted during shipment. Ensure tubes are not rubbing against each other or any sheet metal. Pay close attention to feeder tubes, making sure wire ties on feeder tubes are secure and tight.

## STEP 7. —Make Electrical Connections

⚠ **WARNING**

**ELECTRICAL SHOCK HAZARD**

Failure to follow this warning could result in personal injury or death.

Do not supply power to unit with compressor terminal box cover removed.

24ACA

Be sure field wiring complies with local and national fire, safety, and electrical codes, and voltage to system is within limits shown on unit rating plate. Contact local power company for correction of improper voltage. See unit rating plate for recommended circuit protection device.

**NOTE:** Operation of unit on improper line voltage constitutes abuse and could affect unit reliability. See unit rating plate. Do not install unit in system where voltage may fluctuate above or below permissible limits.

**NOTE:** Use copper wire only between disconnect switch and unit.

**NOTE:** Install branch circuit disconnect of adequate size per NEC to handle unit starting current. Locate disconnect within sight from and readily accessible from unit, per Section 440-14 of NEC.

## ROUTE GROUND AND POWER WIRES

Remove access panel to gain access to unit wiring. Extend wires from disconnect through power wiring hole provided and into unit control box.

⚠ **WARNING**

**ELECTRICAL SHOCK HAZARD**

Failure to follow this warning could result in personal injury or death.

The unit cabinet must have an uninterrupted or unbroken ground to minimize personal injury if an electrical fault should occur. The ground may consist of electrical wire or metal conduit when installed in accordance with existing electrical codes.

## CONNECT GROUND AND POWER WIRES

Connect ground wire to ground connection in control box for safety. Connect power wiring to contactor as shown in Fig. 9.

DISCONNECT  
PER N. E. C. AND/OR  
LOCAL CODES

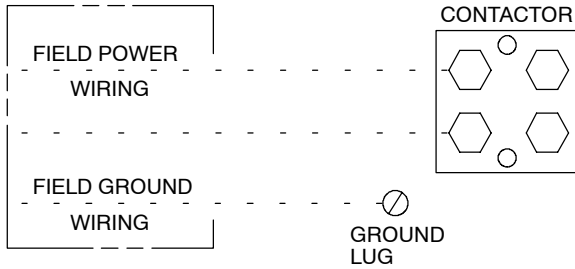

A91056

Fig. 8 — Line Power Connections

## CONNECT CONTROL WIRING

Route 24-v control wires through control wiring grommet and connect leads to control wiring.

Use No. 18 AWG color-coded, insulated (35°C minimum) wire. If thermostat is located more than 100 ft. from unit, as measured along the control voltage wires, use No. 16 AWG color-coded wire to avoid excessive voltage drop.

All wiring must be NEC Class 1 and must be separated from incoming power leads.

Use furnace transformer, fan coil transformer, or accessory transformer for control power, 24-v/40-va minimum.

**NOTE:** Use of available 24-v accessories may exceed the minimum 40-va power requirement. Determine total transformer loading and increase the transformer capacity or split the load with an accessory transformer as required.

## FINAL WIRING CHECK

**IMPORTANT:** Check factory wiring and field wire connections to ensure terminations are secured properly. Check wire routing to ensure wires are not in contact with tubing, sheet metal, etc.

## STEP 8. —Compressor Crankcase Heater

When equipped with a crankcase heater, furnish power to heater a minimum of 24 hr before starting unit. To furnish power to heater only, set thermostat to OFF and close electrical disconnect to outdoor unit.

A crankcase heater is required if refrigerant tubing is longer than 80 ft. Refer to the Longline Guideline Section - Residential Split-System Air Conditioners and Heat Pumps Using Puron® Refrigerant.

## STEP 9. —Install Electrical Accessories

Refer to the individual instructions packaged with kits or accessories when installing.

## STEP 10. —Start-Up



## CAUTION

### UNIT OPERATION AND SAFETY HAZARD

Failure to follow this caution may result in minor personal injury, equipment damage or improper operation.

To prevent compressor damage or personal injury, observe the following:

- Do not overcharge system with refrigerant.
- Do not operate unit in a vacuum or at negative pressure.
- Do not disable low pressure switch in scroll compressor applications.
- Dome temperatures may be hot.



## CAUTION

### PERSONAL INJURY HAZARD

Failure to follow this caution may result in personal injury.

Wear safety glasses, protective clothing, and gloves when handling refrigerant and observe the following:

- Front seating service valves are equipped with Schrader valves.



## CAUTION

### ENVIRONMENTAL HAZARD

Failure to follow this caution may result in environmental damage.

Federal regulations require that you do not vent refrigerant to the atmosphere. Recover during system repair or final unit disposal.

### Follow these steps to properly start up the system:

1. After system is evacuated, fully open liquid and vapor service valves.
2. Unit is shipped with valve stem(s) front seated (closed) and caps installed. Replace stem caps after system is opened to refrigerant flow. Replace caps finger-tight and tighten with wrench an additional 1/12 turn.
3. Close electrical disconnects to energize system.
4. Set room thermostat at desired temperature. Be sure set point is below indoor ambient temperature.
5. Set room thermostat to COOL and fan control to ON or AUTO mode, as desired. Operate unit for 15 minutes. Check system refrigerant charge.

## SEQUENCE OF OPERATION

Turn on power to indoor and outdoor units. Transformer is energized.

On a call for cooling, thermostat makes circuits R-Y and R-G. Circuit R-Y energizes contactor, starting outdoor fan motor and compressor circuit. R-G energizes indoor unit blower relay, starting indoor blower motor on high speed.

**NOTE:** To achieve the rated system performance, the indoor unit or the thermostat must be equipped with a time delay relay circuit.

When thermostat is satisfied, its contacts open, de-energizing contactor and blower relay. Compressor and motors stop. If indoor unit is equipped with a time-delay relay circuit, the indoor blower will run an additional 90 sec to increase system efficiency.

### STEP 11. —Check Charge

#### UNIT CHARGE

Factory charge and charging method are shown on unit information plate. Charge Puron units with cylinder in upright position and a commercial-type metering device in manifold hose. Charge refrigerant into suction line.

**NOTE:** If subcooling charging conditions are not favorable, charge must be weighed in accordance with unit rating plate,  $\pm 0.6$  oz./ft. of 3/8-in. liquid line above or below 15 ft., respectively. Favorable conditions fall within the ranges given on the charging chart on the outdoor unit plate.

**NOTE:** In longline applications, see Application Guideline for special charging requirements.

#### EXAMPLE:

To calculate additional charge required for a 25-ft. line set:  
 $25 \text{ ft.} - 15 \text{ ft.} = 10 \text{ ft.} \times 0.6 \text{ oz./ft.} = 6 \text{ oz.}$  of additional charge.

## COOLING ONLY PROCEDURE

This system requires charging by the subcooling method.

1. Operate unit a minimum of 10 minutes before checking charge.
2. Measure liquid service valve pressure by attaching an accurate gage to service port.
3. Measure liquid line temperature by attaching an accurate thermistor type or electronic thermometer to liquid line near outdoor coil.
4. Refer to unit rating plate for required subcooling temperature.
5. Refer to Table 3. Find the point where required subcooling temperature intersects measured liquid service valve pressure.
6. To obtain required subcooling temperature at a specific liquid line pressure, add refrigerant if liquid line temperature is higher than indicated or reclaim refrigerant if temperature is lower. Allow a tolerance of  $\pm 3^{\circ}\text{F}$ .

### STEP 12. —Final Checks

**IMPORTANT:** Before leaving job, be sure to do the following:

1. Ensure that all wiring is routed away from tubing and sheet metal edges to prevent rub-through or wire pinching.
2. Ensure that all wiring and tubing is secure in unit before adding panels and covers. Securely fasten all panels and covers.
3. Tighten service valve stem caps to 1/12-turn past finger tight.
4. Leave Owner's Manual with owner. Explain system operation and periodic maintenance requirements outlined in manual.
5. Fill out Dealer Installation Checklist and place in customer file.

## TechAssist™ Diagnostics –at–a–Glance

This system is equipped with a system diagnostics tool called the TechAssist™. Follow Table 3 to identify and correct problems in system operation.

**Table 3—TechAssist™ Diagnostics –at–a–Glance**

LED	Description	ON	OFF
Y	Thermostat cooling call	Yes	No
HPS	High Pressure Switch	Closed	Open
LPS	Low Pressure Switch	Closed	Open
<hr/>			
230V	AC Line Power Available	Yes	No
Contactor	Contactor Energized	Yes	No
Compressor	Compressor Running	Yes	No

The diagram shows two ladders. The CONTROL ladder (top) consists of three LEDs: Y, HPS, and LPS, connected in series with arrows pointing from Y to HPS and from HPS to LPS. The POWER ladder (bottom) consists of three LEDs: 230V, Contactor, and Compressor, connected in series with arrows pointing from 230V to Contactor and from Contactor to Compressor.

Note: – Follow arrows to first unlit LED in control (green) ladder or power (amber) ladder to determine problem area.

\*\*\* – For contactor LED to be On, all control LEDs (green) as well as 230V LED (amber) must already be on, and contactor must operate properly

Control Ladder Green LEDs			Power ladder Amber LEDs			Indication	Possible Cause & Quick Trouble–Shooting
Y	HPS	LPS	230V	Contac- tor	Compressor		
Off	Off	Off	Off	Off	Off	– No 230V power to unit – No thermostat call	– Check 230V disconnect/ circuit breaker – Check 230V L1 & L2 wire connections
On	Off	Off	--	Off	Off	– HPS Switch Open	– Check pressures – Check HPS wire connections
On	On	Off	--	Off	Off	– LPS Switch Open	– Check pressures – Check LPS wire connections
On	On	On	Off	Off	Off	– No 230V power to unit	– Check 230V disconnect / circuit breaker – Check 230V L1 & L2 wire connections
On	On	On	On	Off	Off	– Contactor open ***	– Check Contactor and replace if necessary – Check contactor wire connections
On	On	On	On	On	Off	– Compressor not running*	– Check for compressor protector trip, capacitor fault, faulty connections or compressor fault. SEE BELOW.
On	On	On	On	On	On	– Compressor running	– OK
Off	Off	Off	On	Off	Off	– No thermostat call, standby	– OK
Off	Off	Off	On	On	Off	– Contactor stuck closed, compressor tripped	– Check Contactor and replace if necessary – Check wire connections for shorts
Off	Off	Off	On	On	On	– Contactor stuck closed, compressor running	– Check Contactor and replace if necessary – Check wire connections for shorts

\*Compressor not running: If all LEDs are on except the Compressor, this indicates that power is applied to the compressor but it is not running. Check the following sequence:

- 1) Check all compressor wire connections
- 2) Check run capacitor and replace if necessary
- 3) Try starting compressor
- 4) If compressor LED does not come on, then leave unit in standby for up to four hours to allow thermal protector to reset, and all pressures to equalize
- 5) Try starting the compressor again
- 6) If compressor LED comes on, then turns off quickly, investigate starting issues such as low line voltage
- 7) If compressor LED never comes on, compressor may be faulty.

**CARE AND MAINTENANCE**

For continuing high performance and to minimize possible equipment failure, periodic maintenance must be performed on this equipment. Frequency of maintenance may vary depending upon geographic areas, such as coastal applications. See Owner's Manual for information.

**Table 4—Required Liquid—Line Temperature (°F)**

LIQUID PRESSURE AT SERVICE VALVE (PSIG)	REQUIRED SUBCOOLING TEMPERATURE (°F)					
	8	10	12	14	16	18
189	58	56	54	52	50	48
195	60	58	56	54	52	50
202	62	60	58	56	54	52
208	64	62	60	58	56	54
215	66	64	62	60	58	56
222	68	66	64	62	60	58
229	70	68	66	64	62	60
236	72	70	68	66	64	62
243	74	72	70	68	66	64
251	76	74	72	70	68	66
259	78	76	74	72	70	68
266	80	78	76	74	72	70
274	82	80	78	76	74	72
283	84	82	80	78	76	74
291	86	84	82	80	78	76
299	88	86	84	82	80	78
308	90	88	86	84	82	80
317	92	90	88	86	84	82
326	94	92	90	88	86	84
335	96	94	92	90	88	86
345	98	96	94	92	90	88
354	100	98	96	94	92	90
364	102	100	98	96	94	92
374	104	102	100	98	96	94
384	106	104	102	100	98	96
395	108	106	104	102	100	98
406	110	108	106	104	102	100
416	112	110	108	106	104	102
427	114	112	110	108	106	104
439	116	114	112	110	108	106
450	118	116	114	112	110	108
462	120	118	116	114	112	110
474	122	120	118	116	114	112
486	124	122	120	118	116	114
499	126	124	122	120	118	116
511	128	126	124	122	120	118

**24ACA**

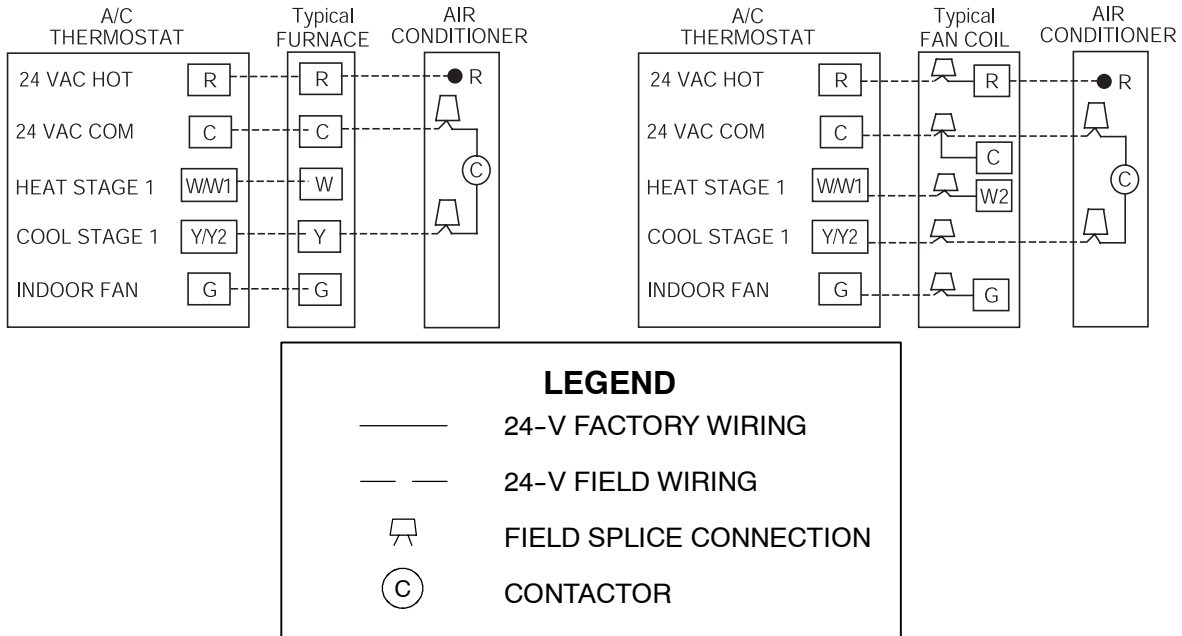

A05379

**Fig. 9 — Generic Wiring Diagrams**  
(See Thermostat Installation Instructions for specific unit combinations)

## PURON® (R-410A) QUICK REFERENCE GUIDE

- Puron refrigerant operates at 50-70 percent higher pressures than R-22. Be sure that servicing equipment and replacement components are designed to operate with Puron
- Puron refrigerant cylinders are rose colored.
- Recovery cylinder service pressure rating must be 400 psig, DOT 4BA400 or DOT BW400.
- Puron systems should be charged with liquid refrigerant. Use a commercial type metering device in the manifold hose when charging into suction line with compressor operating
- Manifold sets should be 700 psig high side and 180 psig low side with 550 psig low-side retard.
- Use hoses with 700 psig service pressure rating.
- Leak detectors should be designed to detect HFC refrigerant.
- Puron, as with other HFCs, is only compatible with POE oils.
- Vacuum pumps will not remove moisture from oil.
- Do not use liquid-line filter driers with rated working pressures less than 600 psig.
- Do not leave Puron suction line filter driers in line longer than 72 hours.
- Do not install a suction-line filter drier in liquid line.
- POE oils absorb moisture rapidly. Do not expose oil to atmosphere.
- POE oils may cause damage to certain plastics and roofing materials.
- Wrap all filter driers and service valves with wet cloth when brazing.
- A factory approved liquid-line filter drier is required on every unit.
- Do NOT use an R-22 TXV.
- If indoor unit is equipped with an R-22 TXV or piston metering device, it must be changed to a hard shutoff Puron TXV.
- Never open system to atmosphere while it is under a vacuum.
- When system must be opened for service, recover refrigerant, evacuate then break vacuum with dry nitrogen and replace filter driers. Evacuate to 500 microns prior to recharging.
- Do not vent Puron into the atmosphere.
- Do not use capillary tube coils.
- Observe all **warnings, cautions, and bold** text.
- All indoor coils must be installed with a hard shutoff Puron TXV metering device.