

# Totaline® UV Air Purifier & Filter

INDOOR AIR QUALITY



Part Number:  
P103-S1000G-25

## The Totaline® S1000G-25 Filter-UV Air Purifier Kills Bacteria And Viruses

The S1000G-25 is a combination Ultraviolet - Filter Air Purifier. The S1000G-25 - is designed to destroy harmful pollutants and biological contaminants. This unit consists of one 16" UVC "J" shaped lamp, two 1" prefilters and one 4" 95% efficient ASHRAE filter. In addition to the patented UV process\*, the S1000G-25 Clean Room option is also available and includes an extra 16" UVC "J" shaped lamp (making a total of two for even more purification), and changing the 95% filter for a 99.97% HEPA filter. The clean room option is typically used for hospitals, day care centers, etc. The S1000G-25 is equipped with a 1750 CFM blower and can be installed into the existing ventilation system or can be used as a stand-alone unit. HEPA filtration is recognized as a great way to remove airborne particulates from the environment. Using both UV and HEPA technology makes the S1000G-25 a great unit for your air purification needs.

- **Warranty:** UV Lamp 12,000 Operating Hours.  
All other parts 5 years.

\* Patent #: 5,833,740

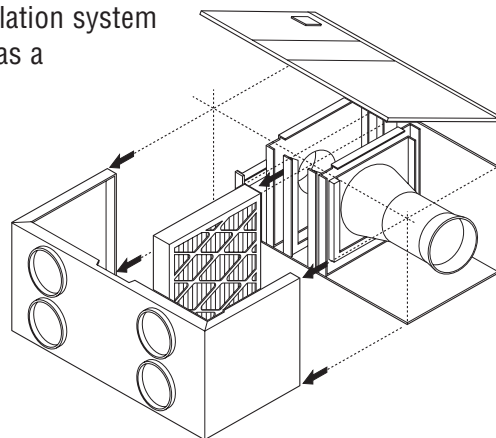

**TOTALINE®**

# UV Air Purifier & Filter

## Totaline® P103-S1000G-25

### Available Accessories:

Part Number	Description
P103-S1000G-25-CRKIT	Clean Room Upgrade Kit
P103-S1000G-25-FILTER	99.97% Replacement Filter For P103-S1000G-25
P103-GERMLAMP006	Replacement UV Lamp

### Specifications:

Outside Dimensions	20" x 20" x 41" (508mm x 508mm x 1041 mm)
Mounting	Three sets of four 1/4" threaded mounting brackets
Weight	59 Lbs. (26.8Kg.)
Air inlets	2 x 8 inch
Air outlets	2 x 8 inch
Power requirements	120Volt, 360 Watts, 60Hz
Blower rating	1750 cfm
Airflow under load	1000+cfm
UV Lamp Dimensions:	"J" type (Proprietary) Ultraviolet Split Lamp 19mm. Dia., 16 in. (406 mm)
Lamp Arc Length:	31.2 in. (793 mm)
Air Exposure Time to UV Lamp- per pass:	43 milli seconds
UV Intensity inside UV Reflector:	8,740 microwatts per/cm <sup>2</sup>
UV Reflector:	10" x 20" Aluminum Reflective Cone
Outlet Noise Level @ 5 feet (no duct attached)	59 dBa
Enclosure Noise Level @ 5 feet	54 dBa
Prefilters (2)	1" Media filter
Main Filter:	19.5" x 19.5" x 4", 90-95% ASHRAE
Chassis & Paint	Aluminum, Powder Coat
Options	Various 19.5" x 19.5" x 4" Media filters Clean Room Option, HEPA Filter

### Other Commercial UV Air Purifiers And Irradiators Available Through Totaline®

Part Number	Description
P103-RTUVL-024	24" UV Lamp
P103-RTUVL-030	30" UV Lamp
P103-CC2020	CoilClean L Shaped Lamps
P103-CT200G	Commercial UV Air Purifier
P103-CMT100G	Ceiling Mounted UV Air Purifier
P103-BIOBARRIER40	40" BioBarrier UV 5 Lamp Array
P103-BIOBARRIER50	50" BioBarrier UV 5 Lamp Array
P103-BIOBARRIER60	60" BioBarrier UV 5 Lamp Array

