

# EACA

Electronic Air Cleaner  
Sizes 0014, 0020, & 2020

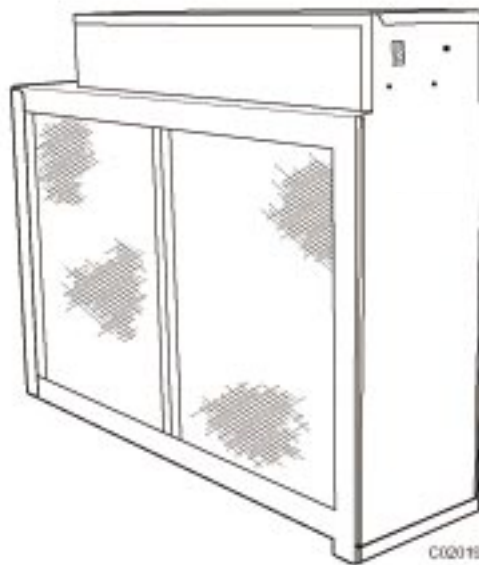

Manual for:  
Installation • Operation • Maintenance

CAUTION: Read installation instructions and rules carefully for safe operation.  
Exercise the usual precautions when working with high voltage.

<b>Table of Contents</b>	<b>Page</b>
Safety Considerations & Introduction	1
Unit specifications	2
Facts you should know about your new Electronic Air Cleaner	
1) Regular dusting & "white dust"	4
2) Ozone	4
3) Air flow sensor operation	5
4) High altitude applications	6
Replacing the ionizing wires	7
Common Q & A	8-9
Maintenance of your Electronic Air Cleaner	10
1) Removing the cells and prefilter	10
2) Washing the cells and prefilter(s)	11
3) Replacing the cells and prefilter(s)	11
Common troubleshooting techniques	12
Installation instructions ( for use by authorized HVAC contractors)	15-29
Technical troubleshooting flowchart	29-30
Replacement part list	31-32

<b>List of figures</b>	<b>Page</b>
Figure 1 Air flow sensor diagram	5
Figure 2 Reducing ozone in high altitude applications	6
Figure 3 Cleaning the ionizing-collector cells	10
Table 1 Symptoms of excessive arcing or zapping	12
Unit dimensions	13
Technical specifications	15
Typical HVAC system configurations	16
Figure 4 Sheet metal transitions	18
Figure 5 Turning vanes from improving air flow	18
Figure 6 Proper installation of cell spacer	19
Figure 7 Proper mounting diagram	21
Figure 8 Wiring the unit to the input power source	22
Figure 9 Electrical schematic diagram	26
Figure 10 Testing the power supply output	28
Troubleshooting flowchart	29-30
Unit p a r t s diagram	31-32

**NOTE:** Read the entire instruction manual before starting the installation.

#### Safety Considerations

Improper installation, adjustment, alteration, service, maintenance, or use can cause explosion, fire, electrical shock, or other conditions which may cause personal injury or property damage. Consult a qualified installer, service agency, or your distributor or branch for information or assistance. The qualified installer or agency must use factory authorized kits or accessories when modifying this product. Refer to the individual instructions packaged with the kits or accessories when installing.

Follow all safety codes. Wear safety glasses and work gloves. Read these instructions thoroughly and follow all warning or cautions attached to the unit. consult local building codes and National Electric Code (NEC) for special requirements.

Recognize safety information. This is the safety-alert symbol . When you see this symbol on unit or in instructions and manuals, be alert to potential for personal injury.

Understand the signal words **DANGER**, **WARNING**, and **CAUTION**. These words are used with the safety alert symbol. **DANGER** identifies the most serious hazards which will result in severe personal injury or death. **WARNING** signifies a hazard which **could** result in personal injury or death. **CAUTION** is used to identify unsafe practices which **would** result in minor personal injury or product and property damage. **NOTE** is used to highlight suggestions that will result in enhanced installation, reliability, or operation.

This manual provides information for location, installation, operation and service. Before installation and use of the air cleaner, carefully read these instructions to insure maximum benefits from the unit and to avoid needless service costs that can result from improper installation.

## INTRODUCTION

This electronic air cleaner is technically known as a two-stage electrostatic precipitator. The air cleaner is designed to remove airborne particulates, including dust, dirt, smoke, pollen, virus, spores, bacteria and mold, from indoor air.

Air movement through the unit is provided by the heating, air conditioning or ventilating system blower. As dirty air enters the air cleaner, the air passes through a metal mesh prefilter. The prefilter prevents lint, pet hair and other large particulates from entering the air cleaner. It is important that these filters be in place to prevent excessive dirt loading of the air cleaner collector cells. These filters extend the time between maintenance of the air cleaner collector cells. This allows the ionizing-collector cells to provide clean air for a longer period between washings.

The prefiltered air then passes through a two-stage Electronic Air Cleaner. In the first stage, all airborne particulate, even submicron size, are electronically charged (positive) as they pass through the ionizer. The ionizer field is set up by a corona discharge emanating from the fine, tightly strung wires suspended between two adjacent flat plates. In the second stage, the charged particulate passes through an intense electrical field established between alternately charged and grounded parallel collector plates. Here, the positively charged particulate is attracted to the negatively ground plates and removed from the air stream.

For a unit diagram and a complete listing of all parts, please see page 31-32.

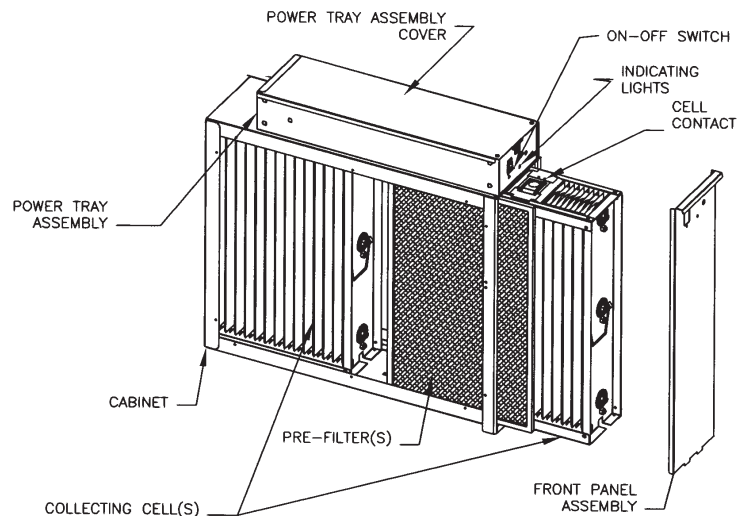

## UNIT SPECIFICATIONS

This air cleaner is easy to install, operate and maintain. Its basic components are the:

### Cabinet

Mounts to existing ductwork; houses the ionizing-collecting cells and prefilters.

### Ionizing-Collector Cells

Collect the dust, dirt and other particulates in the air. They contain the ionizing and collecting sections as described on page 2. The cells must be installed with ionizing wires on the air intake side. A spring contact is located on the top of each cell and must be in position to make contact with the contact board assemblies on the bottom of the power tray assembly.

### Prefilters

Trap large particulates before it enters the ionizing-collector cells.

### Power Tray Assembly

Contains the indicating light, solid state power supply, contact boards and electrical controls including ON/OFF switch and safety interlock switch.

A wiring compartment is provided at the rear of the tray allowing the option to permanently wire the unit directly to a furnace control.

### Air Flow Sensor (AFS)

Installed on certain models, this part brings the unit on by sensing the movement of air within the duct.

## How to Identify Which Air Cleaner Model you own

The model number and serial number for your Electronic Air Cleaner can be found on the data label located on the inside of the access door. This serial number will be a ten (10) digit number.

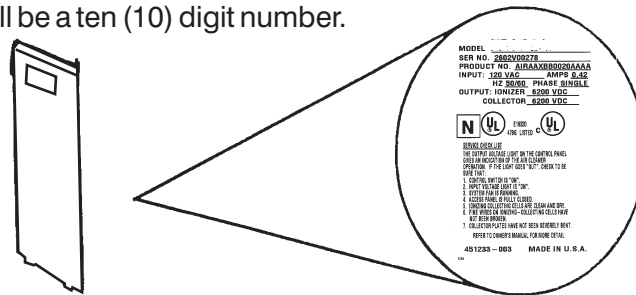

## **FACTS YOU SHOULD KNOW ABOUT YOUR NEW ELECTRONIC AIR CLEANER**

### **Dusting and "White Dust"**

Your new Electronic Air Cleaner will efficiently clean and filter your household air. Unfortunately, it will not eliminate the need for regular dusting of your furniture and belongings. Due to the design of all duct-mounted air cleaners, they can only clean the air that reaches the air cleaner. Therefore, if the particulates are not being carried to the air cleaner in the air stream, the air cleaner cannot remove them from your home.

Occasionally a "white dust" may be noticed in bedrooms or newly furnished rooms. This is mainly composed of lint which, because it is heavier than other particulates, settles before it reaches your unit.. This "white dust" is not mixed with airborne dirt particles, therefore, it is clean and has no staining or soiling properties. However, running the furnace blower continuously, day and night, will help reduce this from occurring.

### **Ozone**

Under normal operating conditions all Electronic Air Cleaners produce minute quantities of ozone as an incidental by-product. In fact, all electronic products, such as televisions, cordless phones and refrigerators, produce some amount of ozone. The average homeowner can detect the smell of ozone concentrations as low as 25 to 100 ppb (parts per billion). The design of this unit has been tested and ozone production is approximately half of the published permissible limits established by the Environmental Protection Agency. These limits recommend that the concentration of indoor ozone not exceed 50 ppb. Ozone is not harmful in these concentrations. In fact, the ozone level in major cities can sometimes reach as high as 100 ppb on a summer day. The addition of optional charcoal after-filters can help reduce this.

Normally, a new unit will produce more ozone than one that has been in operation for several weeks. This is due to sharp corners or manufacturing burrs on the ionizing-collecting cell(s) and is normal. As the Electronic Air Cleaner arcs and zaps, the voltage is vaporizing these areas and tends to round them off. This is part of the breaking-in period of ownership and the issue is self-correcting. Also, high-altitude locations can be more susceptible to noticing the presence of ozone.

An ionizing-collecting cell that has been damaged or bent (the designed spacing between electrically charged and ground components has been decreased) may also produce an abnormal amount of ozone.

**▲ CAUTION:**

Turn OFF power and install lockout tag before beginning any maintenance procedure.

**How the Air Flow Sensor Works (Available on specific models)**

The electronic AFS was designed to provide an efficient and reliable method of controlling the operation of the air cleaner when the dealer is unable to wire the unit directly into the furnace blower. The electronic AFS utilizes a thermistor that heats up to approximately 130°F. The AFS then stabilizes at this temperature and when the furnace blower turns on and air flows through the ductwork, the same vacuum effect pulls cooler air over the hot surface. This air movement cools down the thermistor and this cooling down effect allows the electronic AFS to understand that the furnace blower is moving air and the Electronic Air Cleaner must turn on to provide air cleaning.

If the air cleaner is installed in a location that is dusty and dirty, the sensor on the AFS can become coated with dirt and lint. This coating can insulate the AFS and keep it from operating properly. To clean the thermistor, take a cotton swab dipped in rubbing alcohol and carefully insert it into the hole located on the right hand side of the power pack assembly (when facing the unit). The hole is 3/16 " in diameter and is located on the front of the power tray assembly. Carefully twirl the cotton swab between your fingers, making sure the tip is lightly in contact with the grey disc, cleaning this coating from the thermistor.

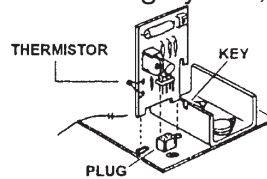

Figure 1

**AFS TROUBLESHOOTING**

It is recommended that the following procedure only be performed by an authorized HVAC contractor. Failure to do so may expose an individual to personal injury

1. Make sure the furnace blower is not operating, the rocker switch is OFF and the circuit breaker is turned OFF.
2. Remove the access door.
3. Remove power tray assembly.
4. Locate the AFS. It is a circuit board with a small grey disc connected to the circuit board by two(2) silver wires (similar to Figure 1). Carefully bend the thermistor so that it is located in the center of the opening and approximately 1/8" from the inside edge of the power pack assembly.
5. Reinstall the power tray assembly and access door.

### **High Altitude Operation**

Because the air is less dense at higher altitudes, there is a possibility of nuisance arcing. The homeowner can quickly and easily correct this condition.

1. Turn the unit OFF and turn off circuit breaker.
2. Remove the two screws that secure the cover to the power tray and remove it from the unit. (The entire power supply tray may be removed from the cabinet by removing two screws from inside the cabinet.) Do not lose these screws.
3. Locate the jumper terminal (see figure 2).
4. With a pair of needle nose pliers, carefully adjust the jumper settings from HIGH to MED. Ensure that the jumper is firmly seated in the terminal.
5. Replace the power tray cover and secure it with the two screws.
6. Replace the access door and turn the unit ON.

This procedure will slightly reduce the output voltage, minimize arcing and reduce ozone production. If the condition does not improve, repeat the above procedure and move the jumper setting from MED to LOW. If this does not correct the situation, contact your local HVAC dealer.

All Electronic Air Cleaners are produced at the factory with the jumpers set in the HIGH position. However, the output voltage may be lowered in any situation where the unit is arcing excessively or there is excessive ozone production.

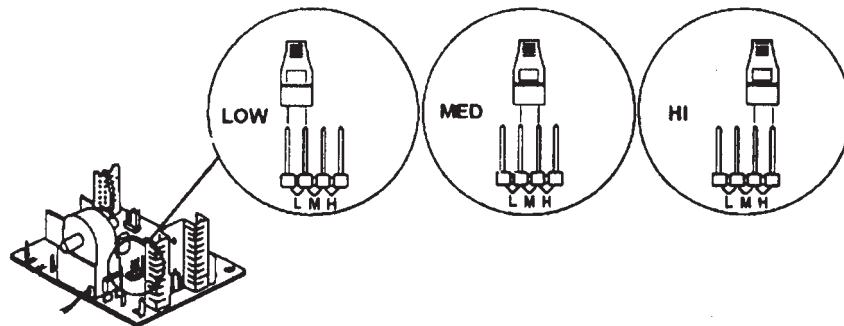

Figure 2

## **REPLACING THE IONIZING WIRES**

Ionizing wire breakage is minimal because of the constant tension design and fixed location of the ionizing wire supports. When an ionizing wire breaks, the efficiency of the Electronic Air Cleaner will decrease slightly. However, the unit will continue to operate with broken ionizing wires as long as the broken wires have not caused a short circuit of the unit. Remove all loose and broken wires as soon as they are identified.

Although the replacement of the ionizing wires can be attempted by a homeowner, it is recommended that a qualified HVAC contractor be contacted for replacement parts and/or servicing. Wires are supplied in a coiled spring configuration, with a clinch nut on each end of the wire. Replacement requires a pair of needle nose pliers. Exercise caution in removing any broken wires in the collector cell. This will prevent accidental shorting of the cell and reduce the need for further maintenance.

Use the following procedure when replacing an ionizing wire.

1. Ensure that all power to the Electronic Air Cleaner is OFF, remove the access door and remove the ionizing-collector cells from the unit.
2. Carefully remove all remains of the broken wire.
3. Grip the new wire at each end of the wire with your thumb and index finger. While stretching the wire to approximately 6" allow one end of the wire to uncoil between your thumb and index finger.
4. Place one end of the wire in the slot of the stainless steel support on the collector cell from the front of the cell. This support is partially covered by the cell brace in front of the support.
5. Grip the other end of the ionizing wire with needle nose pliers and insert the terminated end of the wire into the slot on the support bar of the opposite end of the collector cell.
6. The wire should be tight enough to be self supporting and remain suspended between the two support slots in the support bar.

## Common Questions and Answers

Q. Why isn't my air cleaner cleaning my air?

A. The air cleaner is most likely working just like it was designed. However, many factors can affect the performance of the unit. Are cold air registers located in the ceiling? If so, it will be difficult for the air flow to carry heavier particulates to the air cleaner. If the dirt doesn't get to the air cleaner, it can't be removed from the air. Are both the Red and Green lights illuminated? If not, then the unit may be in need of servicing. Contact your local HVAC dealer for assistance.

Q. It still isn't cleaning my air the way I want it to. What can I do?

A. We recommend that you run the blower continuously so that the air movement will carry the dirt to the air cleaner. Unfortunately, there will always be some dirt that is left behind on the appliances, furniture, etc. Regular dusting is recommended to stir up these pockets of dust so that they can enter the airstream and be removed by the Electronic Air Cleaner.

Q. When I turn on my Electronic Air Cleaner, the lights come on for a couple of seconds and then turn off. The air cleaner isn't working!

A. The air cleaner is fine as long as both the Red and Green lights are coming on. Try turning the HVAC blower OFF and then turning the Electronic Air Cleaner on. This should solve the problem.

Q. What is the zapping noise I'm hearing from my unit? Should I be concerned?

A. The zapping or popping noise that you are hearing is the sound of larger particles being "vaporized" by the ionizing-collector cell. This is normal and is no cause for alarm. As your HVAC system blower moves the air through the ductwork and allows the Electronic Air Cleaner to clean the air, the noise will diminish. However, there will always be instances when larger particles enter the ionizing-collector cell.

Q. Should I hear this zapping noise all the time?

A. All Electronic Air Cleaners will occasionally zap or pop as larger particles pass through the ionizing-collector cells. However, if the sound is constant or is repetitive in nature, then a large particle may have become lodged in the ionizing-collector cells and they may require cleaning. If cleaning the ionizing-collector cells does not stop the noise and there are no large particles trapped in the ionizing-collector cells, then the cause could be a broken/loose ionizing wire, bent collector plate or other mechanical reason. Please contact your local HVAC dealer for assistance.

- Q. What if I no longer hear any popping or zapping noises coming from my unit? Is it still cleaning the air?
- A. If the zapping noises stop and the air cleaner is not in need of servicing, then one of two situations has occurred. First, the Electronic Air Cleaner has successfully removed all larger particles from the air and is cleaning microscopic particles which do not cause the zapping noise. Second, the blower and/or HVAC system is not running and air is not flowing through the ductwork. The Electronic Air Cleaner cannot remove particles if the air stream is not moving.
- Q. I lost power to my home during a storm. Should I worry about the Electronic Air Cleaner?
- A. The most common problem associated with power outages is the unit will not turn on properly after power is restored. If the Red and Green light come on for a couple of seconds and then go off, the unit is OK. Just turn the HVAC blower off, turn the unit ON and then turn the blower back on. If the Red and/or Green light does NOT come on after a storm, the power supply in the Electronic Air Cleaner may be short circuited. Contact a local HVAC contractor for further information.
- Q. My installer told me to keep my HVAC system blower running all the time, but I don't want to increase my power bill. What should I do?
- A. It is recommended that you keep your HVAC system blower running all the time to achieve the maximum air cleaning efficiency. This will allow the Electronic Air Cleaner to do what it is designed to do, which is clean the air. Remember that if the air does not reach the air cleaner, it cannot be cleaned. On average, your Electronic Air Cleaner will use the same amount of electricity as a 55W light bulb. The energy usage of the HVAC system blower will depend on the age of your system , energy costs in your regional location and other variables. The best solution is to try running the HVAC system blower in continuous mode for a month or two to estimate your annual energy costs and base your final decision on what you feel most comfortable with.

## MAINTENANCE OF YOUR ELECTRONIC AIR CLEANER

**! WARNING :** Handle ionizing-collector cells with care as plates can be sharp and cause injury if not handled properly.

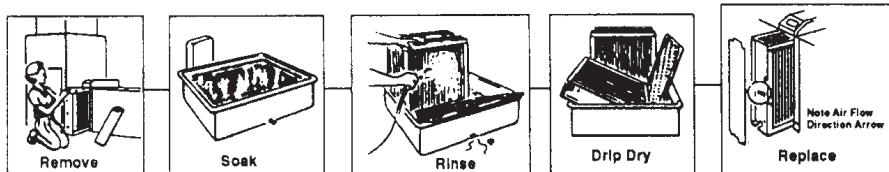

Figure 3

### WASHING CELLS AND PREFILTERS

Regular washing is necessary to ensure proper performance. A thorough washing once every two months will be adequate for most installations. More frequent washing (once a month) may be necessary on some installations (new homes for example) where there is new carpeting, plaster dust, or excessive cigarette smoke (Figure 3).

#### To remove cells and prefilter

1. Push air cleaner switch to the OFF position. Wait 15 seconds. Open door access panel.
2. Carefully remove cells and prefilter(s) and set aside in a safe place.
3. Do not drop the ionizing-collector cell. This could cause damage to the cell plates or ionizing wires and cause excessive arcing and noise.

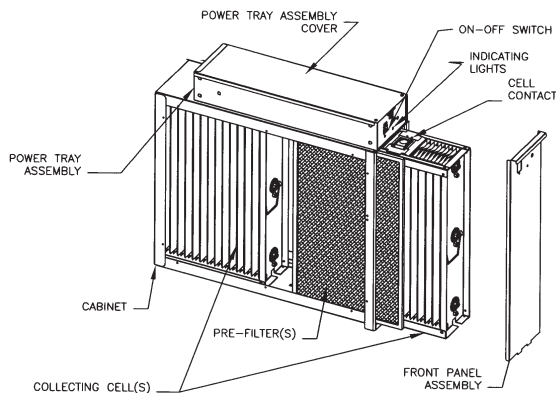

**To wash cells and prefilter(s)**

We suggest that you follow the instructions below to properly and thoroughly clean your collector cells.

1. Place enough hot water in a utility tub to cover the first cell. Dissolve 2 to 4 oz. of granulated automatic dishwasher detergent (not laundry detergent) in the water.
2. Allow the cell to soak for 30 minutes. Agitate it up and down in the solution until it appears clean and remove.
3. Repeat with second cell.
4. Agitate the prefilters up and down in the solution until they appear clean.
5. With a hose, rinse the cells and prefilters. The hose should be held about 10" from the cell plates and at a slight angle for better cleaning results. Be careful not to spray the ionizing wires directly with the hose. The water pressure can cause the wire to snap and break. The cell frame should be thoroughly rinsed along the edges to dislodge any trapped lint or dirt. Carefully wipe a damp cloth or sandpaper (not emery cloth) along the ionizing wires.
6. Stand cells and prefilters up to drain. Let dry two hours. You may experience a slight discoloration of the aluminum collector cells after washing. This is a normal chemical reaction and will not harm your unit or affect its performance.

**To replace cells in air cleaner**

1. Replace prefilter and cells in cabinet. Check that arrow on cells points in same direction as air flows through the duct. (If you have to force it past the positioning screw on bottom, it is probably in the wrong position.)
2. Replace access door (engage tabs on lower edge of door into slots in cabinet). Carefully close door.
3. Turn air cleaner switch to ON.

**COMMON TROUBLESHOOTING TECHNIQUES**

SYMPTOM	POSSIBLE CAUSES	CORRECTIVE ACTION
Rapid arcing or zapping	Broken or loose ionizing wire(s)	Remove broken or loose wire and replace with new wire
	Dirty ionizing-collector cell	Clean as outlined on page 10-11
	Damaged or bent collector plates	Straighten plates with needlenose pliers or replace entire ionizing-collector cell.
Excessive ozone smell	Dirty insulator caps on ionizing-collector cell	Clean with warm soapy water and rinse well
Excessive ozone smell	Air cleaner is wired directly to a 120V power source	Qualified HVAC contractor must install AFS or rewire air cleaner To the HVAC system blower
	Loose high voltage connections	Repair or replace the component
	Radio or television interference	Uncommon occurrence -- check for good common ground for air cleaner
Hissing or sizzling noise	Poor electrical contact	Ensure that there is a good connection between the top of the ionizing-collector cell and the bottom of the contact board assembly Contact HVAC contractor
Green LED light is not ON	No power available	Reset circuit breaker Replace fuse
	Loose wiring at ON/OFF switch	Check for secure connection
	Defective ON/OFF switch	Replace ON/OFF switch
	ON/OFF switch not in ON position	Turn the unit ON
Red LED light is not ON	Loose wiring within power pack assembly	Check for secure connections Contact HVAC contractor
	Broken or shorted electrical component	Contact HVAC contractor
	Excessive dirt build up on ionizing wires	Clean wires with alcohol and allow to dry thoroughly before turning the unit ON
	Contact board assemblies are corroded or carbonized	Replace contact board assembly
	Broken ionizing wire	Remove broken wire and replace with new wire
	Dirty ionizing-collector cell	Clean as outlined on page 10-11
	Foreign object located between collector plates	Remove object from ionizing-collector cell
	Damaged or bent collector plates	Straighten with a pair of needlenose pliers or replace cell
Insulators are corroded or carbonized	Replace insulators or ionizing-collector cell	

Table 1

**UNIT DIMENSIONS - All dimensions in inches (mm)**

**EACA**

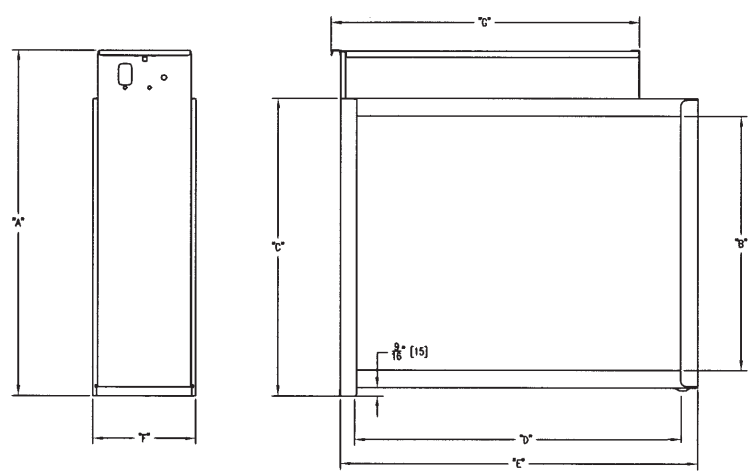

Models	A		B		C		D		E		F		G	
	Inches	MM	Inches	MM	Inches	MM	Inches	MM	Inches	MM	Inches	MM	Inches	MM
0020	24-1/4	616	17-7/8	453	20-15/16	531	22-1/2	572	24-7/8	632	7-1/8	181	21-7/16	545
0014	20-1/4	514	13-7/8	352	16-15/16	429	22-1/2	572	24-7/8	632	7 1/8	181	21-7/16	545
2020	24-1/4	616	17-7/8	453	20-15/16	531	19	483	21-3/8	543	7-1/8	181	18-5/8	473

**WARNING**

Only a trained, experienced serviceman should install this electronic air cleaner. A thorough checkout of the unit installation should be completed before unit operation. Electrical shock can cause serious injury or death.

## TECHNICAL SPECIFICATIONS

(Specifications subject to change without notice.)

MODEL NUMBER-EACA	0014	0020	2020
DIMENSIONS (IN)	20 1/4 x 7 1/8 x 24 7/8	24 1/4 x 7 1/8 x 24 7/8	24 1/4 x 7 1/8 x 21 3/8
AIR FLOW SENSOR INSTALLED	NO	NO	YES
ELECTRICAL INPUT	120V, 60 Hz, 1 PH	120V, 60 Hz, 1 PH	240V, 60Hz, 1PH
MAXIMUM RATED AIR FLOW	1400 CFM (2380 m <sup>3</sup> /hr.)	2000 CFM (3400 m <sup>3</sup> /hr.)	1400 CFM (2380 m <sup>3</sup> /hr.)
MAXIMUM PRESSURE DROP	.11 inch w.g. @1400 CFM	.14 inch w.g. @ 2000 CFM	.11 inch w.g. @ 1400 CFM
CELL WEIGHT (2 CELLS IN EACH UNIT)	10 lbs. each (4.45 kg)	12 lbs. Each (5.45 kg)	9 lbs. Each (4.10 kg)
UNIT WEIGHT	32 lbs (14.6 kg)	36lbs (16.4 kg)	36 lbs. (16.4 kg)
MAXIMUM POWER CONSUMPTION	40 watts	48 watts	40 watts
ELECTRICAL OUTPUT	2.5mADC @ 6200 kVDC	3.2 mADC @ 6200 kVDC	2.5 mADC @ 6200 kVDC
CLASSIFICATION	UL/CUL	UL/CUL	UL/CUL

## TYPICAL MOUNTING POSITIONS

Shaded illustrations are for positioning use only

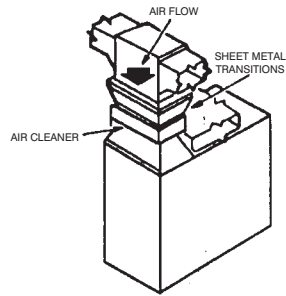

**BASEMENT FURNACE (LOWBOY)**  
Mounted horizontally in return plenum - just above the furnace

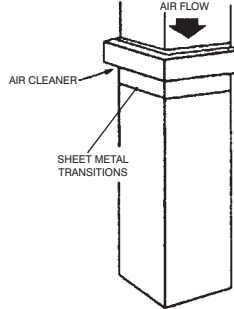

**COUNTERFLOW FURNACE**  
Mounted horizontally in return duct - just above the furnace

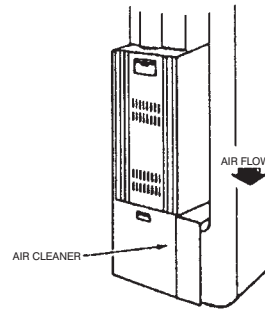

**SPACE SAVER FURNACE (HIGHBOY)**  
Side installation. Cleaner is mounted vertically, where return air enters side inlet of furnace.

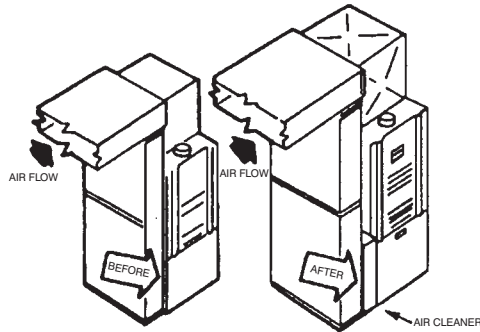

**OFFSET INSTALLATION**  
If there is less than 7-in. for mounting the air cleaner between the duct and the furnace, move the return air drop.

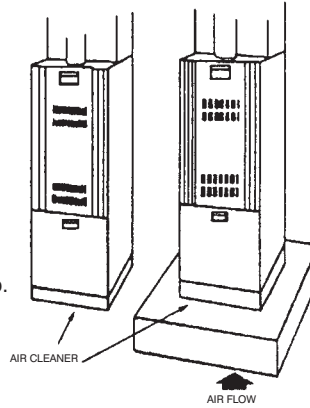

**SPACE SAVER (HIGHBOY)**  
Installation beneath furnace. Cleaner mounts horizontally, where return air enters from below. Raise furnace by installing a suitable wood structure and install air cleaner.

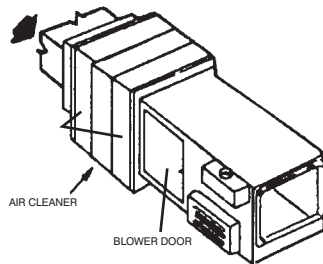

**HORIZONTAL FURNACE**  
Mounted vertically in return duct as close to the furnace as possible

## PLANNING THE INSTALLATION

### **Application**

The air cleaners are used in forced air heating cooling and ventilating systems. The air cleaner should be installed in the system so that all the system air is circulated through the air cleaner. The air cleaner will only remove the airborne contaminants delivered to it. Maximum performance is obtained when the system blower is set for continuous operation.

### **Installation Requirements**

The best location for the air cleaner is in the return air duct next to the blower compartment. In this location, the blower motor and cooling coils will be kept clean.

### ***DO NOT INSTALL THE AIR CLEANER IN THE DISCHARGE AIR DUCT.***

Before installing the air cleaner, consider the application and type of HVAC system present. Refer to the section entitled **Typical Mounting Positions**, for the most common types. If a transition between the ductwork and air cleaner is required, refer to section entitled **Transitions**. The unit must be readily accessible for periodic inspection and cleaning of the prefilters and electronic cells to maintain maximum efficiency and trouble-free operation.

### **Air Conditioning**

The air cleaner should be installed upstream of the cooling coil. This will keep the coil clean and reduce air conditioning coil maintenance. Improved cooling efficiency is the result and directly affects energy costs. A clean coil, will reduce utility costs. If the air cleaner is downstream of the cooling coil, condensation will form on the cooled collector plates when the air conditioner cycles. This will allow water droplets to form on the collector plates and cause nuisance arcing. Arcing will reduce air cleaner efficiency and reduce the life of the high voltage power supply.

### **Humidifiers**

An evaporative humidifier can be mounted upstream of the air cleaner. It is best to install an atomizing humidifier downstream of the air cleaner because hard water salt deposits and water droplets may damage the air cleaner. If an atomizing humidifier must be mounted upstream of the air cleaner:

1. Mount it as far upstream as possible. (Recommended at least 6 feet.)
2. Install a standard disposable furnace filter between the humidifier and the air cleaner to trap water droplets and hard water salts.
3. Clean the air cleaner more frequently to prevent a hard water salt buildup.

### **Outdoor Air**

When outdoor air is added to the return air duct, sufficient heat should be added to maintain the return air temperature at 40°F (4°C) minimum. Lower temperatures can cause ionizer wire failure.

### **Atomizing Humidifiers**

If an atomizing humidifier is installed, it must be mounted downstream of the air cleaner.

1. Mount the humidifier as far downstream as possible. It is recommended a distance of at least 10 feet to reduce the possibility of excessive arcing as water droplets pass through the Electronic Air Cleaner.
2. Install a standard disposable furnace filter between the humidifier and the air cleaner to trap water droplets and hard water deposits.
3. Clean the air cleaner more frequently to prevent a hard water buildup.

### **Sheet Metal Installation**

The Electronic Air Cleaner is adaptable to all new or existing residential forced air furnace and cooling systems.

### **Transitions**

If the air duct does not fit the air cleaner cabinet opening, gradual transitions are recommended to reduce air turbulence through the air cleaner and maximize efficiency. Not more than 20° (about 4" per running foot) of expansion should be used on each side of the transition fitting (Figure 4).

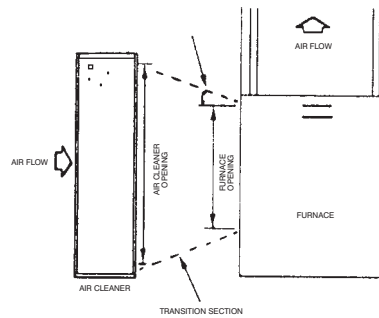

Figure 4

### **Outdoor Air**

When outdoor air is added to the return air duct, sufficient heat should be added to maintain the return air temperature at 40°F (4°C) minimum. Lower temperatures can cause ionizer wire failure.

### **Turning Vanes**

If the air cleaner is installed adjacent to a 90° duct elbow, add turning vanes inside the duct to improve air distribution across the face of the air cleaner (Figure 5). Failure to follow the recommendation can reduce the efficiency of the Electronic Air Cleaner.

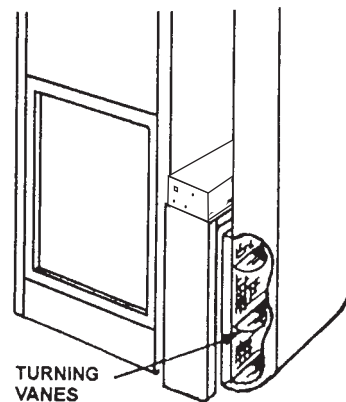

Figure 5

## SELECT LOCATION FOR AIR CLEANER

Remember to select a location that is readily accessible for periodic inspection and cleaning of this air cleaner. Allow a minimum of 24" clearance in front and 12" clearance above the air cleaner for component removal and service space. For complete dimensions required refer to the section entitled **UNIT DIMENSIONS**.

## DIRECTION OF AIR FLOW THROUGH THE AIR CLEANER

This air cleaner is set up for left to right air flow when you are facing the access door.

For right to left air flow, follow these directions:

1. Remove the prefilter(s) and cells from the cabinet. A plastic positioning spacer is located inside the bottom of the cabinet. This spacer is secured to the cabinet using a #6-32 round head Phillips drive thread cutting screw to assure installation of the cells in the proper position with respect to air flow (Figure 6).

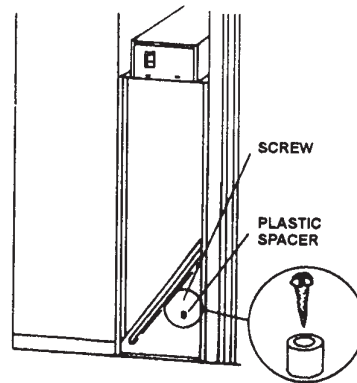



Figure 6

2. Remove the screw and reposition the spacer in the alternate hole at the bottom of the cabinet.
3. Replace the screw to insure the plastic spacer is not accidentally knocked out of place during normal maintenance. It must be installed in the hole provided closest to the air leaving side of the cabinet. Seal the unused hole with duct tape.
4. Remove the cell handle and reattach to the opposite end of the cell. Turn cells around, replace in cabinet and replace prefilters on the air entering side. The directional arrows on the cell end plates must point in the direction of air flow.

## INSTALLATION

 **CAUTION:** Only a trained, experienced serviceman should install this electronic air cleaner. The power supply should be removed before installation. To remove the power supply, remove the two (2) screws (See Figure 7) in the top front of the cabinet. Remember to keep this hardware for reinstallation of the power supply when the air cleaner installation is complete. A thorough checkout of the unit installation should be completed before unit operation.

### PHYSICAL INSTALLATION OF THE AIR CLEANER

This Electronic Air Cleaner can be installed in any position, except with the access door facing down. The section entitled **TYPICAL MOUNTING POSITIONS** show examples of proper air cleaner mounting with a variety of furnace installations.

Prior to installing this product...

1. Read rules and instructions carefully for safe operation. Failure to follow them could damage the product or cause a hazardous condition.
  2. Check the ratings given on the product to make sure it is suitable for your application.
  3. Select a location for the air cleaner.
  4. Remove the old furnace filter and discard.
  5. The air cleaner cannot remove existing dirt from the blower and ducts. Clean the area thoroughly before you begin.
  6. Remove unit access panel, and slide the prefilters and ionizing-collecting cells out of the cabinet. Place them safely aside with the warranty and registration card.
- NOTE:** The following is a typical installation of the air cleaner on a highboy furnace. You may have to alter the installation to fit your particular application.

7. Locate the cabinet in the cold air return duct so that all of the return air flows through the unit (Figure 6). If the furnace and air cleaner openings are different, use a transition (Figure 4).

8. Mounting holes are provided for ductwork attachment (Figure 7). The .140" holes are sized for #8 sheet metal screws, or 1/8" rivets. If the adjoining ductwork is flanged, install the screws so that the screw heads are inside the cabinet. This will prevent damage to the prefilters during removal and installation after cleaning.

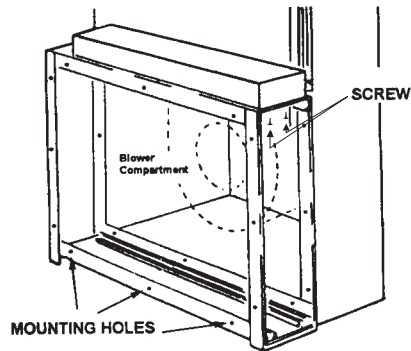

Figure 7

9. After the unit has been secured, seal seams air tight with duct tape or caulking.

**ATTENTION:** On Electronic Air Cleaners that have the air flow sensor installed at the factory, be especially careful not to cover the air flow sensor orifice when sealing the air cleaner and ductwork. This hole is located on the right hand side of the enclosure that holds the power pack assembly (when facing the unit). The hole is 3/16" in diameter and is located on the front of the power tray assembly. In applications with minimum air flow, it is helpful to seal any openings on the power tray assembly or cabinet. This will increase the velocity of air flowing over the air flow sensor, enabling the air flow sensor to turn the Electronic Air Cleaner on and off. The only opening required for actuation of the air flow sensor is the 3/16" diameter hole previously described.

10. Refer to the section entitled **DIRECTION OF AIR FLOW**.

11. Install prefilters and ionizer-collector cells.

12. Reinstall power tray assembly into the cabinet.

13. Reinstall unit access panel.

## ELECTRICAL INSTALLATION

All wiring must comply with applicable local and national codes.

### ⚠ CAUTION:

Be sure all incoming power is OFF before beginning any procedures.

### ⚠ CAUTION:

The following instructions are for use by qualified personnel only.

### ⚠ WARNING:

The following procedures will expose hazardous live parts. Disconnect power between checks and proceed carefully. Electrical shock can cause injury or death.

The Electronic Air Cleaner (without the AFS installed at the factory) is designed to take advantage of the integrated accessory control panel available on most furnaces. The 120V Electronic Air Cleaner tap on the furnace will provide power to the air cleaner only when the circulating air blower is in operation.

Read the instructions in the furnace installation manual carefully before attempting installation or operation. Failure to follow these instructions may result in improper installation and therefore void warranty.

An optional (on 120v model) electronic air flow sensor kit is available if the air cleaner is not equipped with an AFS. This air flow sensor will sense the air movement within the duct and turn the Electronic Air Cleaner on and off accordingly.

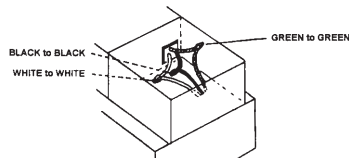

Figure 8

### WIRING PROCEDURE

This air cleaner is powered by providing power to pigtail leads at field wiring compartment (see knock-out holes) located at the rear of the power pack assembly (See Fig. 8).

1. Turn air cleaner OFF using ON/OFF switch located on front panel.
2. Remove power pack cover plate by removing front door and two screws holding assembly to the top of the air cleaner.
3. Make wiring connections inside junction box area (See Fig. 8). Remove knock-out and use conduit or other approved methods to supply input power. Connect ground wire to clip.
4. Replace the power supply cover plate and secure with screws removed from step 2.
5. Replace the unit door to the front of the air cleaner.
6. Air cleaner will now operate when door is in place, ON/OFF rocker switch is in the ON position and input voltage is present in the junction box. The following should be completed to supply input power to the air cleaner.

### FURNACE APPLICATION

It is recommended to use EAC 1 and EAC 2 terminals when provided by the furnace circuit board. These outputs will provide 120 vac whenever the blower motor is energized.

Furnace circuit boards without EAC 1 and EAC 2 terminals MUST use alternate methods to supply to supply power to the air cleaner. Options include Sail Switch, Isolation relay or Optional AFS (Air Flow Sensor). Air cleaner should only operate when blower motor is running.

### ⚠ CAUTION

This unit cannot be powered directly from blower motor leads. Voltages can exceed 190vac for 120-v. motors or possibly double with 240-v. fan coil motors.

### FAN COIL APPLICATION of 0014 or 0020 Models (120-v.)

If EAC 1 and EAC 2 terminals are provided by fan coil circuit board, refer to fan coil data to determine voltage output. Most fan coils do not provide 120-v. at these terminals. Alternate methods may be needed to convert fan coil supply voltage to 120-v. for the cleaner. A 240-v. to 120-v step down transformer (60 v.) will be needed in most applications. Sail Switch, Isolation relay or Optional AFS (Air Flow Sensor) may also be needed.

### FAN COIL APPLICATION of 2020 Model (240-v.)

The Model 2020 is a 240-v. power supply model designed to match your fan coil. To install this model with a 240-v. fan coil:

### ⚠ CAUTION

This unit cannot be powered directly from blower motor leads. Back EMF (electro magnetic field) voltages can reach 400 vac for 240-v. fan coil motors.

1. Turn air cleaner OFF using ON/OFF rocker switch located on front panel.
2. Remove power pack cover plate by removing front door and two screws holding assembly to the top of the air cleaner.
3. Make wiring connections inside junction box area (See Fig. 8). Remove knock-out and use conduit or other approved methods to supply input power. Connect ground wire to clip.
4. Replace the power supply cover plate and secure with screws removed from step 2.
5. Replace the unit door to the front of the air cleaner.
6. Air cleaner will now operate when door is in place, ON/OFF rocker switch is in the ON position and input voltage is present in the junction box.

## SYSTEM CHECKOUT



**WARNING:** The following procedures should be conducted by a qualified HVAC contractor or repair person ONLY. These procedures will expose hazardous electrically energized charged components. Disconnect power between checks and proceed carefully.

1. The HVAC system blower should be turned OFF.
2. Switch the ON/OFF rocker switch to the ON position. The bright red segment of the rocker switch should be visible.
3. Inspect both the Green INPUT POWER light and the Red CELL ENERGIZED light:
  - If the unit has an AFS installed, the lights should go out in approximately 20 to 60 seconds. This is the normal time for the electronic air flow sensor to complete its stabilization period. Both lights will come back on when the HVAC system blower begins to operate. See the section entitled **HOW THE AIR FLOW SENSOR WORKS** for more information
  - If the unit is wired directly to the HVAC system blower, the lights will not come on until the blower begins to operate. In this case, the electronic air cleaner will stay on as long as the ON/OFF switch is in the ON position and the blower is operating.
  - If the unit is wired directly to a dedicated 120V power source, the lights will come on immediately and stay on for as long as the ON/OFF switch is in the ON position, regardless of the HVAC system blower operation. This type of installation is NOT recommended due to the excessive production of ozone. See the section entitled **FACTS YOU SHOULD KNOW ABOUT YOUR ELECTRONIC AIR CLEANER - OZONE** for more information.
4. Wait approximately one (1) minute and turn the HVAC system blower ON. Most thermostats have a setting that will allow you to run the fan manually. If not, then set the thermostat so that either hot or cold air begins to flow through the ductwork.
5. The Green INPUT POWER light and Red CELL ENERGIZED light should come on, if the unit is wired directly to a dedicated 120V power source, the lights will already be on and will not be affected by the HVAC system blower operation (see Step 3).
6. Check to make sure that the Red CELL ENERGIZED light goes out when the following conditions occur:
  - Cell access panel is removed
  - Rocker switch is switched to the OFF position
  - HVAC system blower is not running.

## TROUBLESHOOTING



### **CAUTION:**

- These procedures should only be attempted by a qualified HVAC technician or electrician.
- Risk of personal injury could occur by attempting to troubleshoot or repair this unit by untrained persons.
- Exercise the usual precautions when working with high voltage.
- When the circuit has been de-energized, always discharge any residual current in the secondary with an insulated handle screwdriver.
- Always ground power supply and ionizing-collecting cell when bench testing.

### **Recommended Service Tools**

- Screwdriver, 8" common with insulated handle (plastic)
- Screwdrivers Phillips #1 and #2 with plastic insulated handles
- Needle nose pliers
- Multimeter
- High voltage probe

### **Indication of Electrical Trouble**

The air cleaner is equipped with a Red CELL ENERGIZED light for indicating proper unit operation. When the unit is in normal operation (with the HVAC system fan running, access door in place and rocker switch in the ON position) and the Red CELL ENERGIZED light is not lit, the problem is a shorted secondary. Although failure of the indicating light itself should not be overlooked, this condition is unusual and rather remote.

## PRIMARY CIRCUIT WITH FURNACE BLOWER OPERATING

If there is supply line voltage at the connections and no input voltage to the power supply, the outage can be located by checking operation of the safety switch and the interconnecting wiring with a multimeter. Refer to Circuit Diagram, (Figure 9) to check operation of the switches.

Following these steps to test for proper operation of the circuit board and power supply assembly:

1. Ensure that the circuit breaker controlling the furnace blower is in the ON position and the main fuse is not open.
2. The power supply board has a built-in internal fuse to protect the 24V transformer. It can be checked visually by inspecting the fuse. If the fine wire inside the fuse is broken, this indicates a problem in the 24V circuit of the power supply board. Do NOT replace this fuse. The entire power supply board must be replaced. The purpose of the fuse is not to protect the power supply board, but to function as a troubleshooting feature of the product and to protect the transformer from damage.
3. If the fuse is NOT blown, check the ON/OFF switches and safety interlock switch for proper engagement and operation. This can be completed using a volt ohm millimeter on a scale that will measure ohms as low as 1.0. If you are using the recommended meter previously mentioned in this manual, set the meter to read 200 ohm and proceed with Steps 4 through 6.
4. Remove the fuse. Connect one lead to the test pin located directly beside the wire that connects the ON/OFF switch to the power supply board. Connect the other lead to the fuse connection closest to the front panel.
5. Turn the ON/OFF switch to the ON position and depress the safety interlock switch. The meter should have the capability of reading levels as low as 1.0 ohm.
6. If there is no reading on the meter, begin the process of elimination by disconnecting the wire from the test point and connecting it to the terminal with the blue wire located on the safety interlock switch. Depress the safety interlock switch. If the reading on the meter is greater than 1.0 ohm, the safety interlock switch is defective and must be replaced. If the reading on the meter is less than 1.0 ohm, the ON/OFF switch is defective and must be replaced.

## SECONDARY CIRCUIT

### IONIZING-COLLECTING CELL

The cell is electrically energized through a contact terminal located at the top center of the cell. The ionizing wires and alternating collector plates are electrically charged while the interleaving plates are grounded.

If the space between the charged and grounded plates is bridged with conductive or semi-conductive material, a short circuit develops. The bridging or short may be caused by damaged plates, or foreign material lodged between/on the components. Since the cell should be periodically removed from the unit to wash away collected dirt, it is susceptible to physical damage. The cell also contains the ionizing wires which, due to their function, have been designed with minimal structural support and are susceptible to breakage. However, trouble related to a shorted collector cell is readily shown by the Red CELL ENERGIZED light and can be quickly isolated by a simple procedure.

To determine if a short exists in one or both of the collector cells, turn the Electronic Air Cleaner OFF and remove both electronic cells from the cabinet. Shut the door and repower the unit. If the Red CELL ENERGIZED light comes on, an electrical short exists in one or both of the electronic cells. Replace the cells in the unit, one at a time, to determine which cell is shorted.

Most troubles in the cell can be visually detected and corrected (page 12 - Table 1).

**NOTE:** The ionizer collector cells are not designed for field repair. Ionizing wires and insulators can be field replaced. It is not recommended that you attempt to replace other cell components (i.e. Collector plates, end plates, ionizer supports).

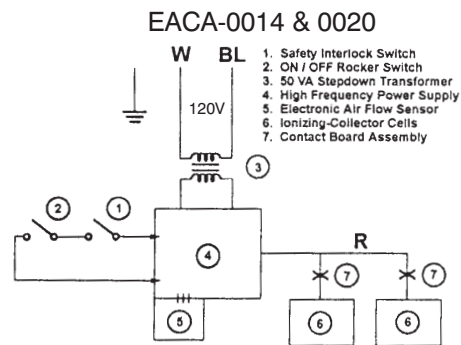

Figure 9A

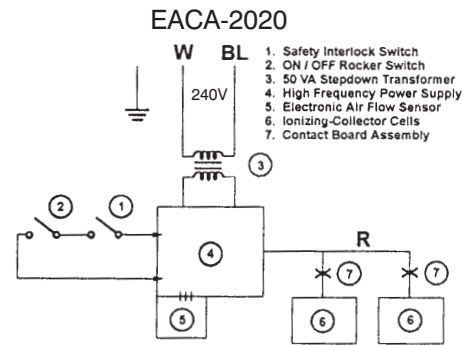

Figure 9B

## CHECKING THE POWER SUPPLY

If the output light remains out with the collector cells removed from the cabinet, the power supply is defective. Specific problems on the power tray assembly can be isolated by using a multimeter and high voltage probe to check the output voltages.

To check the secondary circuit, a high voltage meter is required. See the section entitled RECOMMENDED SERVICE TOOLS. To check for proper operation, it is imperative that the procedure be followed as outlined below:

1. Make sure the furnace blower is operating, the control switch is on and input voltage is 120 volts, 60 Hz.
2. Remove front door assembly panel.
3. Remove power pack access cover.
4. Check the high voltage contact board assembly(s) for damage or carbon tracking.



**NOTE:** The cell contacts should be visually checked for corrosion, excessive dirt build up, and electrical arc tracking (Carbon path from stainless steel spring to grounded metal). Clean or replace as required.

5. Make connections from the high voltage probe to the multimeter in accordance with the operator's manual. The meter should be set for reading DC voltage on the 20 volt full scale.
6. Attach the high voltage probe ground lead to the cabinet. While depressing the safety switch lever, touch the ionizer wire support bar with end of the high voltage probe (Figure 10). The meter reading should be 6.2 kVDC  $\pm$  .2 kVDC.
7. If no voltage is measured, remove the first cell and check the second cell. The meter should read 6.2 kVDC  $\pm$  .2 kVDC.
8. If proper voltage is measured, the first cell is shorted. Refer to Table 1, on page 12.

9. If no voltage is present, remove the second cell. Install cell number one and measure voltage as described above. If voltage is present, the second cell, which is now out of the cabinet, is shorted. Refer to Table 1 on page 12.
10. If no voltage is present, remove both cells and measure the power supply output. While depressing the safety switch, touch the end of the high voltage probe to either the front or rear contact board assembly (Figure 10). The meter should read 6.2 kVDC or higher.
11. If no voltage is present, check the power supply. Set the multimeter for reading AC voltage at 200 volt full scale and attach meter test leads.
12. While depressing the safety lever, touch the two transformer output lead junctions to the power supply board with the meter leads and read the meter.
13. If there is no output voltage from 24 volt transformer, replace the 24 volt transformer and power supply board.

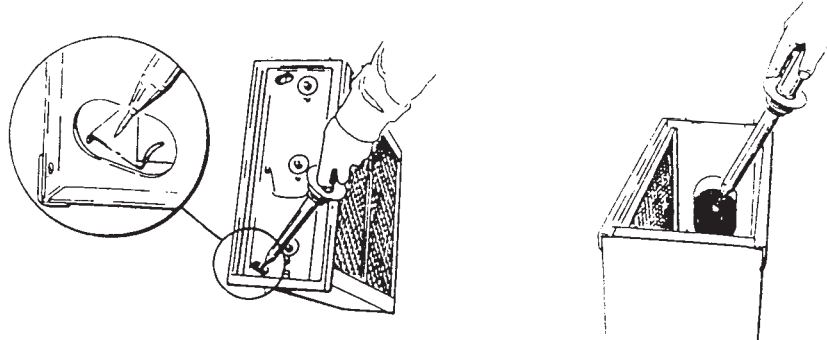
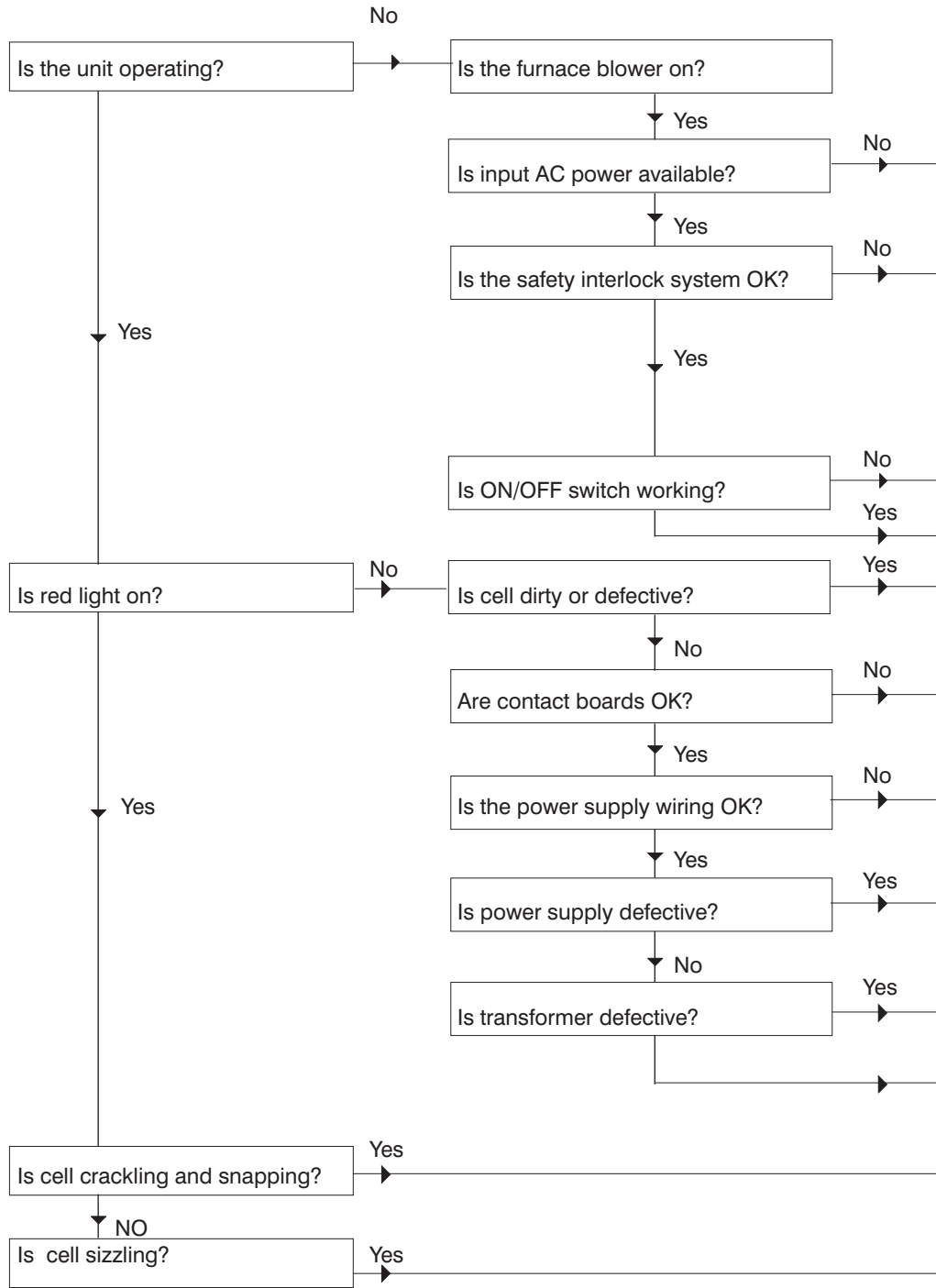

Figure 10

## TROUBLE SHOOTING THE DUCT MOUNT ELECTRONIC AIR CLEANER



**WARNING:**

The following steps will expose hazardous live parts. Disconnect power between checks and proceed carefully.

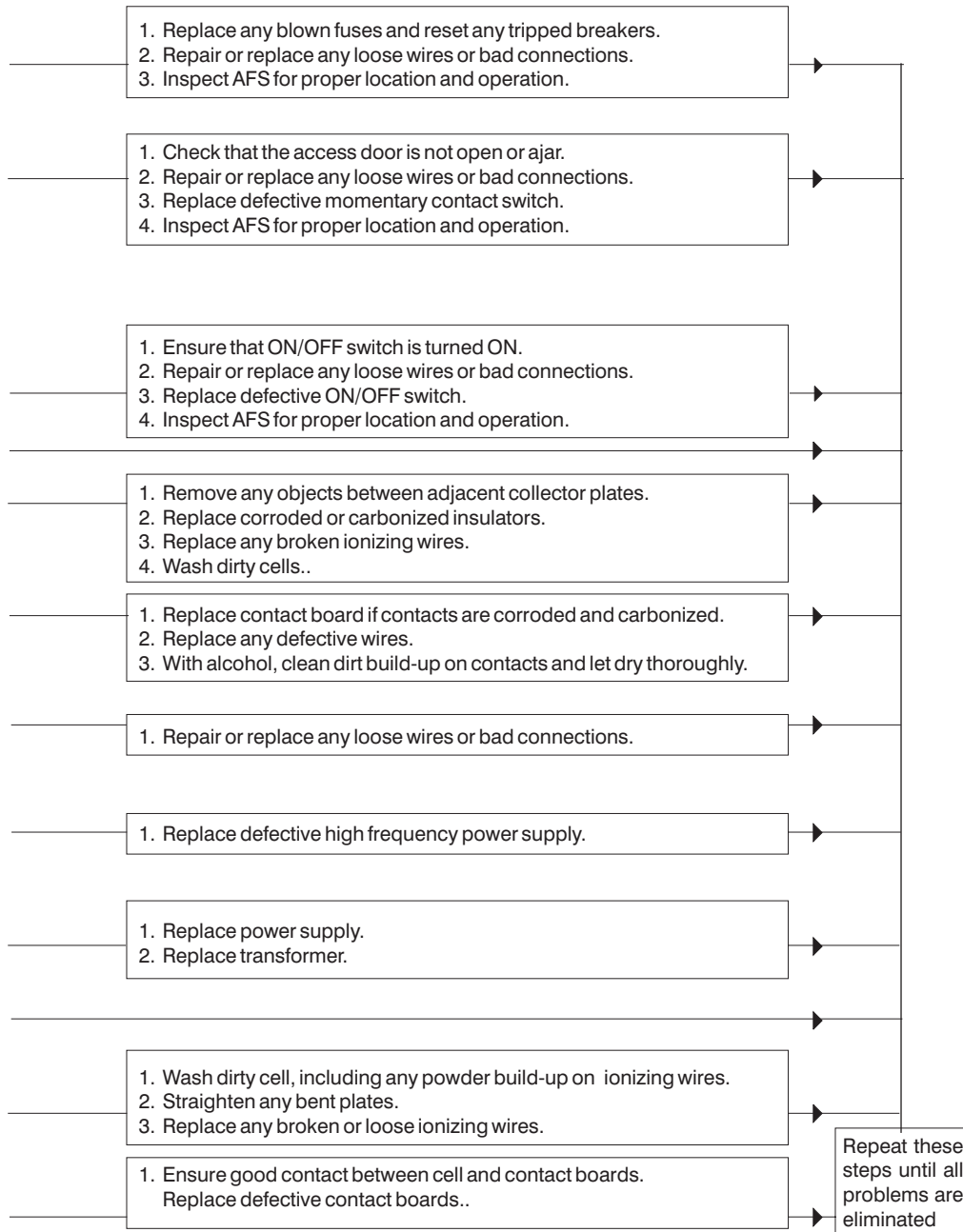

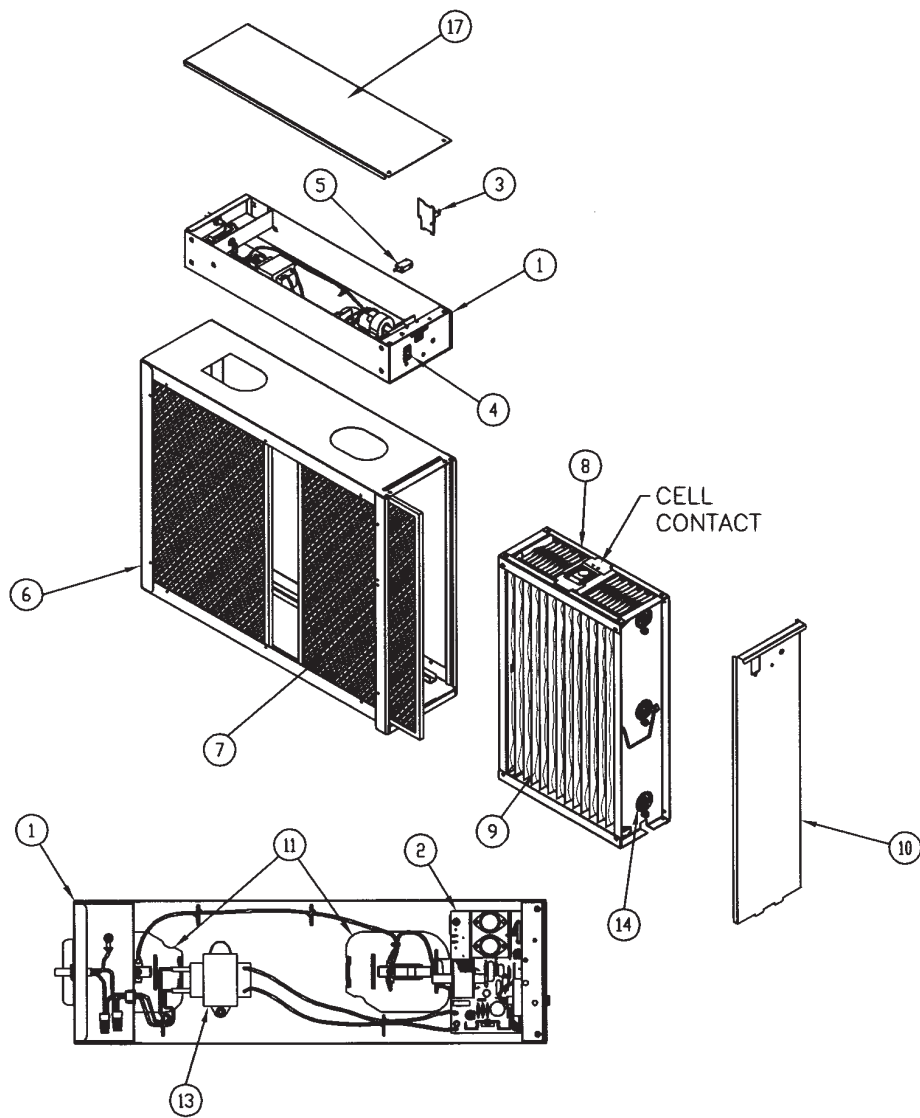

# EACA

## EACA PARTS LIST

REF. DESCRIPTION NO..
1. Power Tray Assembly (W/ AFS) 120V
1A. Power Tray Assembly (W/ AFS) 240V
1B. Power Tray Assembly (W/O AFS)120V
2. High Frequency Power Supply
3. Electronic Air Flow Sensor (Optional)
4. ON/OFF Switch
5. Interlock Switch
6. Cabinet Assembly
7. Pre-Filter (2/ package)
8. Cell, Ionizing-Collecting
9. Ionizing Wire Assembly (Full Set / package)
10 Front Panel Assembly
11. Contact Board Assembly (2/ package)
12. Charcoal Filter (optional, not shown)(2/ package)
13. Stepdown Transformer 120V to 24V (0014 & 0020)
13A. Stepdown Transformer 240V to 24V(2020)
14. Insulator (6/ package)
15. Cell Key (not shown)
16. Power Tray Cover

### OWNER RESPONSIBILITIES

**The completion and return of the Warranty Registration Card is a condition precedent to warranty coverage and performance. This warranty is not valid unless the warranty card is completed and mailed to the factory within fifteen (15) days of equipment installation.**

## Warranty

**Five-Year Limited Warranty** - This Product is warranted to be free from defects in material and workmanship. If Defect appears within **Five** years from the date of original installation, whether or not actual use begins on that date, product is warranted. If product installation criteria meets this standard, a new or remanufactured part, at the manufacturer's sole option, to replace any defective part will be provided without charge for the part itself; PROVIDED the defective part is returned to the distributor through a qualified servicing dealer.

Limited Labor Allowance - If service call on this unit must be made in the first 120 days from original date of installation a \$25.00 (USD) labor allowance will be given. If Power Supply must be replaced in the first 120 days after original installation date a \$50.00 (USD) labor allowance will be given.

THIS WARRANTY DOES NOT INCLUDE LABOR OR OTHER COSTS-OTHER THAN THAT SPECIFIED ABOVE incurred for diagnosing, repairing, removing, installing, shipping, servicing or handling of either defective parts or replacement parts. Such costs may be covered by a separate warranty provided by the installer.

THIS WARRANTY APPLIES ONLY TO PRODUCTS IN THEIR ORIGINAL INSTALLATION LOCATION AND BECOMES VOID UPON REINSTALLATION.

LIMITATIONS OF WARRANTIES – ALL IMPLIED WARRANTIES (INCLUDING IMPLIED WARRANTIES OF FITNESS FOR A PARTICULAR PURPOSE AND MERCHANTABILITY) ARE HEREBY LIMITED IN DURATION TO THE PERIOD FOR WHICH THE LIMITED WARRANTY IS GIVEN. SOME STATES DO NOT ALLOW LIMITATIONS ON HOW LONG AN IMPLIED WARRANTY LASTS, SO THE ABOVE MAY NOT APPLY TO YOU. THE EXPRESSED WARRANTIES MADE IN THIS WARRANTY ARE EXCLUSIVE AND MAY NOT BE ALTERED, ENLARGED, OR CHANGED BY ANY DISTRIBUTOR, DEALER, OR OTHER PERSON WHATSOEVER.

ALL WORK UNDER THE TERMS OF THIS WARRANTY SHALL BE PERFORMED DURING NORMAL WORKING HOURS. ALL REPLACEMENT PARTS, WHETHER NEW OR REMANUFACTURED, ASSUME AS THEIR WARRANTY PERIOD ONLY THE REMAINING TIME PERIOD OF THIS WARRANTY.

### **THE MANUFACTURER WILL NOT BE RESPONSIBLE FOR:**

1. Normal maintenance as outlined in the installation and servicing instructions or owners manual including filter cleaning and/or replacement and lubrication.
2. Damage or repairs required as a consequence of faulty installation, misapplication, abuse, improper servicing, unauthorized alteration or improper operation.
3. Failure to start due to voltage conditions, blown fuses, open circuit breakers or other damages due to the inadequacy or interruption of electrical service.
4. Damage as a result of floods, winds, fires, lightning, accidents, corrosive environments or other conditions beyond the control of the Manufacturer.
5. Parts not supplied or designated by the Manufacturer, or damages resulting from their use.
6. Manufacturer products installed outside the continental U.S.A., Alaska, Hawaii, and Canada.
7. Electricity or fuel costs or increases in electricity or fuel costs from any reason whatsoever including additional or unusual use of supplemental electric heat.
8. ANY SPECIAL INDIRECT OR CONSEQUENTIAL PROPERTY OR COMMERCIAL DAMAGE OF ANY NATURE WHATSOEVER. Some states do not allow the exclusion of incidental or consequential damages, so the above may not apply to you.

This warranty gives you specific legal rights, and you may also have other rights which may vary from state to state.

---

**Manufacturer reserves the right to discontinue, or change at any time, specifications or designs without notice and without incurring obligations.**