

This horizontal N-Coil is designed to provide the highest standard of reliability and durability. The CK3B coil casing is unpainted embossed galvanized steel. The cabinet is fully insulated to minimize energy loss.

The CK3B is designed for application with horizontal furnaces. The bi-directional airflow allows for either horizontal-right or horizontal-left furnace fit-up. This coil is ideally suited for either attic or crawl space installation.

Our advanced manufacturing methods provides a better bond of the aluminum fins and copper tubing for improved heat transfer. The coils are approved for air conditioning or heat pump application in the horizontal configuration.

The CK3B coil includes a removable refrigerant control metering device for improved serviceability over check valves and expansion devices used in conventional coils. Sweat-type connections are furnished for installation of the refrigerant tubes. Enhanced Quality Control procedures eliminate contaminants from the coil manufacturing process. Improved design techniques minimize galvanic action. The CK3B may be used, as is, with R-22 or Puron® systems.

The coil is designed to provide improved condensate removal. The robust, corrosion resistant, condensate pan has brass inserts in the primary and secondary drain connections and meets FHA requirements.

A full line of Tin-Plated copper coil models is available. "T" models are built with special hairpins—Tin-Plated to resist both general pitting corrosion and excessive indoor corrosion—Formicary Corrosion. (Formicary Corrosion is an industry phenomenon).

MODEL NUMBER NOMENCLATURE

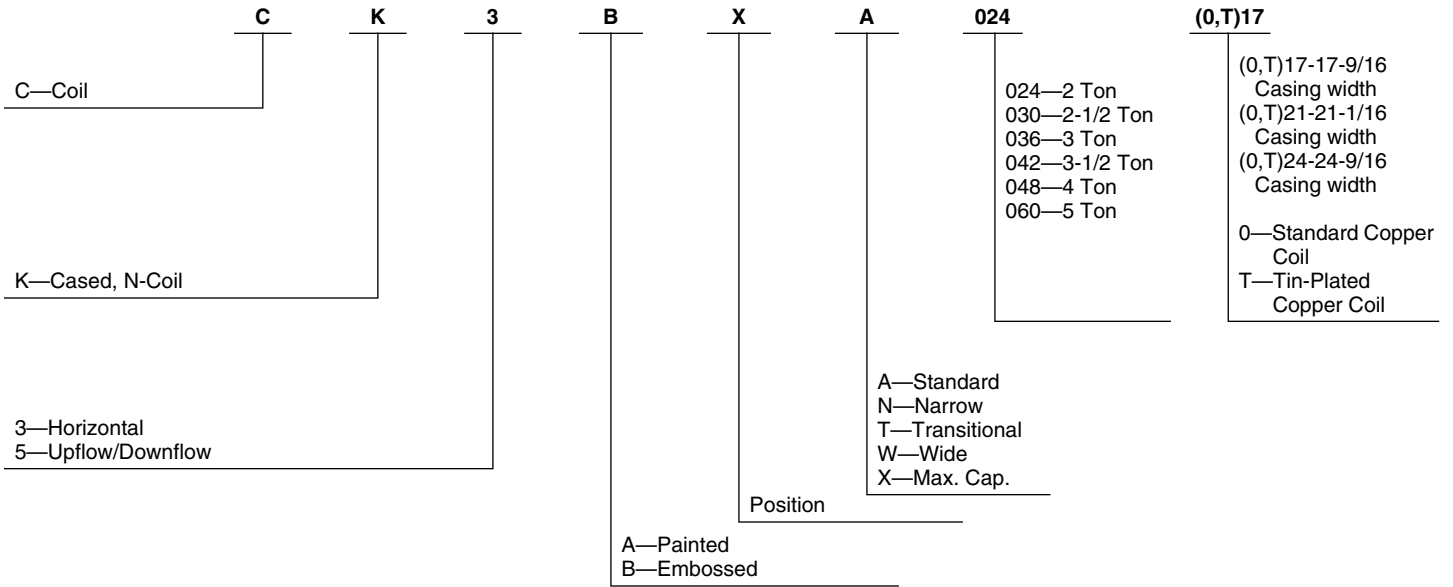

CERTIFICATION APPLIES ONLY WHEN
USED WITH PROPER COMPONENTS
AS LISTED WITH ARI

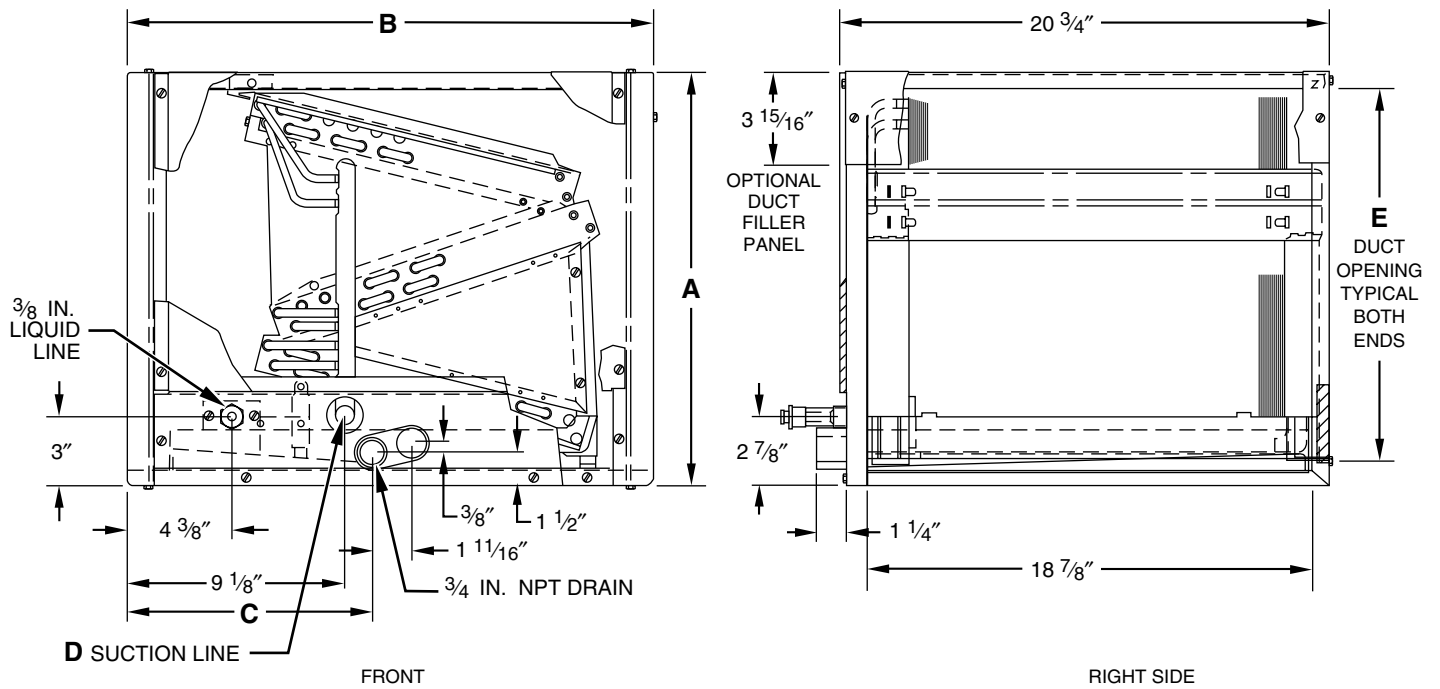

A97521

DIMENSIONS (In.)

UNIT	A	B	C	D	E	SHIPPING WEIGHT Lb
	In.	In.	In.	In.	In.	
CK3BXA024(0,T)17	17-9/16	19-1/16	10-1/16	5/8	16	37.0
CK3BXA030(0,T)17	17-9/16	19-1/16	10-1/16	3/4	16	40.5
CK3BXA036(0,T)17	17-9/16	22-1/16	10-1/4	3/4	16	45.5
CK3BXA042(0,T)21	21-1/16	22-1/16	10-1/4	7/8	19-1/2	47.0
CK3BXA048(0,T)21	21-1/16	22-1/16	10-1/4	7/8	19-1/2	51.0
CK3BXA060(0,T)24	24-9/16	28-1/8	13-3/16	7/8	23	64.0

NOTE: For the 10th digit position in the model number, 0 = standard copper and T = tin-plated copper.

COOLING CAPACITIES (MBH)

UNIT SIZE	INDOOR COIL AIR		SATURATED TEMPERATURE LEAVING EVAPORATOR (°F)														
			30			35			40			45			50		
	CFM	EWB	TC	SHC	BF	TC	SHC	BF	TC	SHC	BF	TC	SHC	BF	TC	SHC	BF
A024	600	72	38.7	17.9	0.00	35.4	16.4	0.00	32.0	15.0	0.13	28.1	13.3	0.08	23.7	11.6	0.07
		67	32.6	19.5	0.07	29.1	17.9	0.06	25.6	16.3	0.06	21.5	14.5	0.05	16.6	12.5	0.06
		62	27.0	20.9	0.05	23.4	19.2	0.05	19.8	17.4	0.05	16.2	15.5	0.08	13.3	13.3	0.18
	800	72	44.0	20.4	0.21	40.4	18.9	0.17	36.8	17.3	0.13	32.4	15.6	0.11	27.2	13.7	0.10
		67	37.4	22.8	0.10	33.5	21.1	0.10	29.5	19.4	0.09	25.0	17.5	0.08	19.7	15.4	0.09
		62	30.6	25.0	0.07	27.0	23.2	0.08	23.4	21.4	0.09	19.7	19.3	0.12	16.6	16.6	0.23
	1000	72	47.9	22.3	0.18	44.0	20.7	0.17	40.1	19.2	0.16	35.5	17.4	0.14	30.0	15.4	0.13
		67	40.7	25.5	0.13	36.6	23.8	0.13	32.4	22.0	0.12	27.3	20.0	0.11	21.9	17.9	0.12
		62	33.7	28.6	0.10	30.0	26.7	0.11	26.2	24.9	0.12	22.7	22.5	0.17	19.4	19.4	0.28
A030	750	72	54.4	25.3	0.00	48.7	22.7	0.00	43.1	20.1	0.00	36.6	17.3	0.07	29.3	14.5	0.06
		67	45.1	26.5	0.07	39.1	23.7	0.07	33.2	20.9	0.06	26.7	18.1	0.05	20.0	15.2	0.08
		62	36.0	27.3	0.05	30.5	24.5	0.06	25.0	21.8	0.07	19.7	19.0	0.09	16.1	16.1	0.21
	1000	72	64.1	29.5	0.00	57.7	26.7	0.00	51.2	23.9	0.19	43.9	20.9	0.12	35.2	17.6	0.10
		67	53.6	31.8	0.11	46.8	28.7	0.10	40.1	25.6	0.10	32.3	22.3	0.09	24.1	18.8	0.11
		62	43.4	33.4	0.10	36.9	30.3	0.10	30.4	27.2	0.10	24.3	24.0	0.12	20.1	20.1	0.26
	1250	72	72.1	33.0	0.00	64.7	29.9	0.00	57.3	26.8	0.20	49.4	23.7	0.15	40.1	20.3	0.14
		67	59.6	35.8	0.14	52.4	32.7	0.14	45.3	29.5	0.13	36.8	25.9	0.13	27.5	22.0	0.15
		62	49.0	38.4	0.14	42.0	35.2	0.13	35.0	32.1	0.13	28.6	28.4	0.16	23.7	23.7	0.30
A036	900	72	63.4	29.6	0.00	57.2	26.8	0.00	50.9	23.9	0.00	44.3	21.0	0.00	36.3	17.9	0.00
		67	52.1	31.0	0.00	46.0	28.1	0.00	39.8	25.1	0.00	32.8	22.1	0.00	24.9	18.8	0.01
		62	42.8	32.7	0.00	36.7	29.6	0.00	30.5	26.6	0.01	23.9	23.0	0.04	19.2	19.2	0.18
	1200	72	75.1	34.7	0.00	67.8	31.6	0.00	60.5	28.5	0.05	52.1	25.1	0.03	43.4	21.8	0.02
		67	61.6	37.2	0.02	54.5	34.0	0.02	47.5	30.8	0.02	39.3	27.3	0.02	30.2	23.4	0.04
		62	51.1	40.2	0.02	44.0	36.7	0.03	36.9	33.2	0.03	29.3	28.9	0.08	24.2	24.2	0.22
	1500	72	83.3	38.5	0.17	75.5	35.3	0.13	67.6	32.1	0.09	58.5	28.5	0.06	48.4	24.8	0.06
		67	69.4	42.5	0.06	61.3	38.9	0.06	53.1	35.4	0.05	44.4	31.7	0.05	34.5	27.5	0.07
		62	56.6	46.2	0.04	49.3	42.5	0.06	42.0	38.8	0.07	34.3	34.3	0.11	28.8	28.8	0.25
A042	1050	72	75.4	35.0	0.00	68.0	31.8	0.00	60.7	28.6	0.02	52.7	25.3	0.00	43.6	21.7	0.00
		67	62.1	37.3	0.00	55.0	34.0	0.00	47.8	30.7	0.00	39.3	26.9	0.01	30.2	23.1	0.03
		62	51.5	39.8	0.01	44.2	36.2	0.01	36.9	32.7	0.02	29.1	28.3	0.06	23.7	23.7	0.20
	1400	72	87.8	40.6	0.18	79.4	37.1	0.13	71.0	33.6	0.07	61.3	29.8	0.05	51.0	25.9	0.05
		67	72.9	44.4	0.05	64.4	40.7	0.04	55.9	36.9	0.04	46.7	33.0	0.04	36.1	28.5	0.06
		62	60.0	48.3	0.03	52.0	44.3	0.05	44.0	40.3	0.06	35.5	35.5	0.10	29.7	29.7	0.24
	1750	72	96.3	44.6	0.16	87.4	41.1	0.13	78.5	37.5	0.11	67.9	33.5	0.09	55.9	29.1	0.09
		67	80.8	50.1	0.08	71.5	46.1	0.08	62.2	42.2	0.08	51.9	37.9	0.08	40.9	33.4	0.10
		62	65.7	55.1	0.07	57.6	50.9	0.08	49.5	46.6	0.10	41.7	41.7	0.15	35.0	35.0	0.28
A048	1200	72	79.8	36.9	0.00	72.6	33.7	0.00	65.4	30.6	0.12	57.0	27.1	0.08	47.5	23.4	0.07
		67	66.6	39.8	0.07	59.1	36.4	0.06	51.7	33.0	0.06	43.2	29.3	0.05	33.3	25.2	0.07
		62	55.2	42.8	0.06	47.6	39.1	0.06	40.0	35.4	0.06	32.2	31.3	0.08	26.7	26.7	0.20
	1600	72	91.0	42.1	0.22	83.0	38.7	0.18	75.0	35.4	0.13	65.4	31.7	0.11	54.5	27.6	0.10
		67	76.7	46.9	0.10	68.1	43.1	0.10	59.5	39.4	0.09	50.1	35.4	0.09	39.4	31.0	0.11
		62	62.7	51.0	0.08	54.9	47.2	0.09	47.1	43.4	0.10	39.3	39.0	0.13	33.1	33.1	0.25
	2000	72	99.2	46.1	0.19	90.7	42.7	0.17	82.2	39.4	0.15	72.0	35.5	0.14	60.0	31.2	0.13
		67	84.0	52.6	0.13	74.8	48.8	0.13	65.7	44.9	0.12	55.1	40.5	0.12	44.0	36.0	0.13
		62	69.0	58.5	0.11	60.8	54.3	0.12	52.6	50.2	0.14	45.4	45.4	0.18	38.5	38.5	0.30
A060	1600	72	101.0	46.7	0.00	90.8	42.2	0.00	80.4	37.6	0.12	69.1	33.0	0.08	56.0	28.0	0.07
		67	83.8	49.9	0.07	73.5	45.2	0.07	63.1	40.5	0.06	51.1	35.3	0.06	38.0	29.8	0.08
		62	68.7	53.0	0.07	58.2	48.0	0.07	47.7	43.0	0.07	38.2	37.6	0.11	31.6	31.6	0.24
	2000	72	113.0	52.2	0.00	102.0	47.4	0.00	90.4	42.6	0.14	77.5	37.5	0.11	63.5	32.3	0.10
		67	94.0	56.8	0.10	82.6	51.8	0.10	71.2	46.8	0.09	58.5	41.3	0.10	43.7	35.2	0.11
		62	77.0	61.2	0.09	66.0	56.0	0.10	55.1	50.7	0.10	45.0	44.7	0.15	37.3	37.3	0.28
	2400	72	123.0	56.6	0.26	111.0	51.6	0.21	98.4	46.7	0.16	84.2	41.2	0.13	69.4	35.8	0.13
		67	103.0	62.8	0.13	89.9	57.4	0.13	77.3	52.0	0.12	64.3	46.5	0.12	48.3	40.0	0.14
		62	83.0	68.4	0.11	72.2	63.0	0.12	61.4	57.5	0.13	51.1	51.1	0.18	42.5	42.5	0.32

See notes on page 5.

CFM — Cubic Ft per Minute
EWB — Entering Wet Bulb (°F)
LWB — Leaving Wet Bulb (°F)
TC — Total Cooling Capacity 1000 Btuh
SHC — Total Sensible Capacity 1000 Btuh
BF — Bypass Factor
MBH — 1000 Btuh

NOTES:

- Contact manufacturer for cooling capacities at conditions other than shown in table.
- Formulas:

$$\text{Leaving db} = \text{entering db} - \frac{\text{sensible heat cap.}}{1.09 \times \text{CFM}}$$

Leaving wb = wb corresponding to enthalpy of air leaving coil (h_{LWB})

$$h_{LWB} = h_{EWB} - \frac{\text{total capacity (Btuh)}}{4.5 \times \text{CFM}}$$

where h_{EWB} = enthalpy of air entering coil.

- Direct interpolation is permissible. Do not extrapolate.
- SHC is based on 80°F db temperature of air entering coil.
Below 80°F db, subtract (Correction Factor x CFM) from SHC.
Above 80°F db, add (Correction Factor x CFM) to SHC.
- All data points are based on 10°F superheat leaving coil.
- Bypass Factor = 0 indicates no psychometric solution. Use bypass factor of next lower EWB for approximation.

BYPASS FACTOR	ENTERING AIR DRY BULB TEMPERATURE (°F)					
	79	78	77	76	75	Under 75
	81	82	83	84	84	Over 85
	Correction Factor					
0.10	0.98	1.96	2.94	3.92	4.91	Use formula shown below
0.20	0.87	1.74	2.62	3.49	4.36	
0.30	0.76	1.53	2.29	3.05	3.82	

Interpolation is permissible.

$$\text{Correction Factor} = 1.09 \times (1 - \text{BF}) \times (\text{db} - 80)$$

COIL STATIC PRESSURE DROP (In. WC)

UNIT SIZE	BULB	AIR QUANTITY (CFM)					
		600	700	800	900	—	—
A024	WET	0.08	0.10	0.13	0.16	—	—
	DRY	0.06	0.08	0.11	0.13	—	—
A030	WET	0.08	0.12	0.15	0.19	0.23	—
	DRY	0.08	0.10	0.14	0.17	0.21	—
A036	WET	0.16	0.19	0.23	0.27	0.32	—
	DRY	0.13	0.17	0.21	0.25	0.29	—
A042	WET	0.18	0.21	0.24	0.27	0.31	—
	DRY	0.14	0.17	0.20	0.23	0.26	—
A048	WET	0.19	0.22	0.25	0.28	0.31	—
	DRY	0.18	0.21	0.24	0.27	0.30	—
A060	WET	0.19	0.22	0.24	0.26	0.28	0.30
	DRY	0.18	0.20	0.21	0.24	0.26	0.28

**CHECK-FLO-RATER®
Piston Chart**

Coil CK3B	Piston No.
024	59
030	67
036	70
042	78
048	84
060	90

TYPICAL N-COIL HORIZONTAL INSTALLATIONS

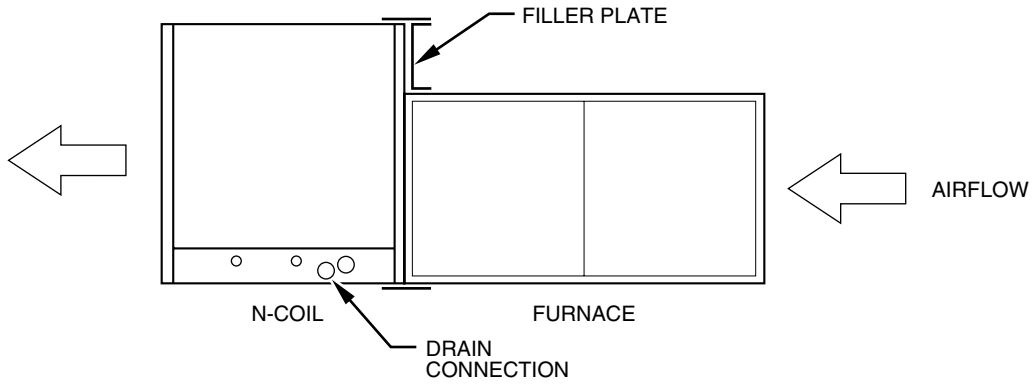

A97203

Horizontal Left

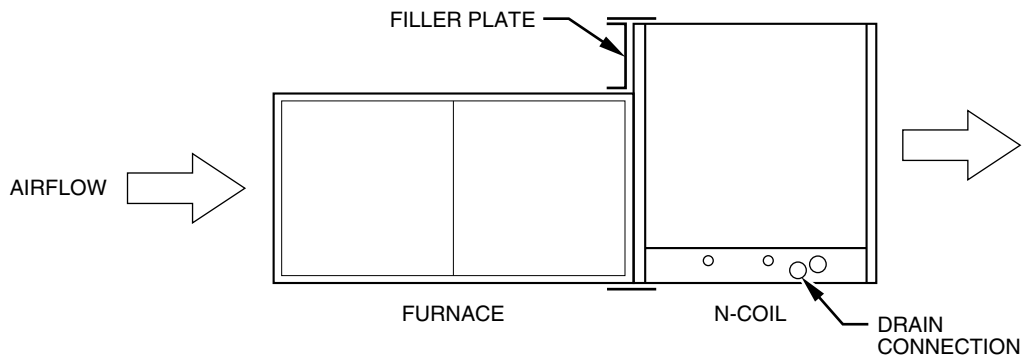

A97037

Horizontal Right

Guide specifications

**Evaporator N Coil
CK3B
2 to 5 Tons Nominal**

GENERAL

Indoor Evaporator Coil must:

- Consist of a design containing three coil slabs to allow for reduced coil height.
- Have all components tested with mineral oil and Polyol Ester oils.
- Have grooved tubing and enhanced fins for improved efficiency.
- Have two drain connections containing brass fittings for a safe and leaktight installation.
- Have a drain pan, which is not capable of rusting.
- Have a drain pan with a steep slope to allow quick drainage of condensate into the drain connection.
- Must have a drain connection at the same level as the bottom of the pan to prevent standing water.
- The coil casing must be insulated.
- Must have passed burst pressures of 2100 PSI.

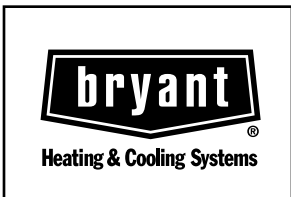

SPECIFICATIONS SUBJECT TO CHANGE WITHOUT NOTICE

UNIT MUST BE INSTALLED IN ACCORDANCE
WITH INSTALLATION INSTRUCTIONS

Cancels: PDS CK3B.24.4